

Collaborative Virtual Environments for Group Support Systems



Studying the effect of space on GSS

Eindhoven, June 2008

**Collaborative Virtual Environments
for Group Support Systems:
Studying the effect of space on
group support systems**

by

Julio Cesar MOLINA ORREGO

BSc Electronic Engineering —2004
Student identity number 0619091

in partial fulfilment of the requirements for the degree of

**Master of Science
in Operations Management and Logistics**

Supervisors:

Prof. dr. ir. van Genuchten, M.J.I.M., TU/e, IS

dr. ir. H.A. Reijers, TU/e, IS

Prof. dr. Douglas Vogel, CityU, Hong Kong

TUE. Department Technology Management.
Series Master Theses Operations Management and Logistics

Subject headings: collaboration, electronic meeting system, group support systems, virtual world

Abstract

This study describes the design and implementation of tools in a virtual world for studying the effect of space in-group support systems. The research follows the design-science paradigm in which a prototype is built, then tested gathering feedback and finally corrections are made starting the cycle again. Specifically, three applications inside the virtual world *SecondLife* were built for brainstorming, organizing ideas and for decision-making. Then, the tools were tested in face-to-face meetings with professionals from real companies as well as with participants geographically distributed around the world during virtual meetings. The results show the effects of space on aspects of group support systems applications like user interface and structure of the electronic meeting process.

Preface

I want to thank my professors for all that they represented to me. A big part of the commitment to my project was due to the intrinsic motivation that I got from professor van Genuchten. The way in which he helped me to manage the different situations of the project was outstanding. Undoubtedly, I learned skills for project management that can only be taught by examples. He did more than only giving advices during meetings; he was a dynamic actor of my project always looking for new and better possibilities. He was more than a professor, he was a real mentor.

About professor Hajo I could say that he is one of the most precise professors that I had during my studies. I realized it in the courses that I followed with him. His constructive critics were valuable for improving the rigor of my project.

Similarly, I want to thank Tony Adams for his constant contribution in the realization of the virtual meetings. In the same way, to the professors Douglas Vogel, Anne-Françoise Rutkowski and Carol Saunders, for their input during the development of the tools as well as the research design.

Finally, I want to thank Angela, Loly, Paty, Agny and the rest of my friends for their emotional support during these long two years. Special thanks to Ocean for MAMS... Yalan adam!!!

Julio Cesar Molina Orrego
June 2008

Management Summary

Introduction

Comprehensively supporting teams technologically, especially in global contexts, is not easy. A problem in virtual teams is lack of presence and its consequences on team performance and satisfaction. Virtual worlds offer an additional presence dimension of technological support for teams. For example, *SecondLife* [50] is a virtual environment (within which real-life experiences can be attained) that has a range of spatially-oriented support opportunities for teams including aspects of visualization through avatars and sense of presence, as well as text and audio interaction. However, little is known about the impact and implications of use of virtual worlds for group support. In its native state, *SecondLife* is particularly weak in providing structured recorded support for team activities such as brainstorming, idea organization and voting. Group Support Systems (GSS) have historically focused on exacting the type of support that *SecondLife* lacks. However, aspects of GSS have not extended into virtual world domains.

Research Question

How can space provided by virtual worlds affect group support systems?

Sub-questions

1. How can GSS applications be implemented inside a virtual world?

Specifically, it is desired to see how the interface can be designed in order to support *the visualization of the parallel contribution* and *visualization of the process*.

2. How do people experience the characteristics of virtual worlds that can influence GSS?

Particularly, it is desired to see to what extent the users consider the 3D interface easy to use and understandable. Similarly, it is desired to see if a 3D interface increases the sociability of GSS tools. Additionally, it is investigated whether the users think that space provided by virtual worlds helps brainstorming, idea organizing and decision making.

Research Design

Design-science paradigm is used. It brings together aspects of artifact development and evaluation in several iterations until a desired state is reached. In particular, three GSS tools in *SecondLife* were built and their use for supporting group tasks in both face-to-face and distributed contexts was systematically evaluated. This report describes that research and presents implications for both research and practice.

Tools Developed

The aim was to create three applications that allowed studying the impact of space on Group Support Systems: a quantitative tool for supporting voting processes, a qualitative tool for brainstorming and a qualitative tool for organization of ideas (these last two were combined in a bigger qualitative tool). The goal was not to replicate existing GSS but to see how the notion of space could be exploited.

The quantitative tool is shown in figure I.a. The idea was to use a voting platform on a floor the size of 10 meters x 10 meters. The platform is set up in a 10 x 10 grid on both the X and Y axis. To vote on an issue each avatar positions itself on the grid. The tool detects the position of each avatar on the grid and computes the x/y coordinates on a 10-point scale for both axes. At the same time the tool averages the coordinates of all avatar's positions on both axes.

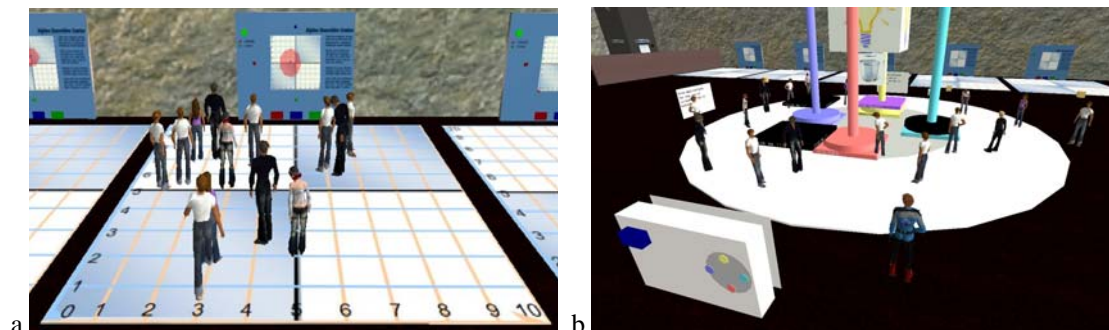

Figure I. a. Multi-criteria tool for decision making, and b. Brainstorming and idea organizing tool.

The qualitative tool was developed with the purpose of supporting brainstorming and organization of ideas. The main idea about the tool was to give the feeling of working in a group in which each individual action has a particular effect on the main results. Thus, it was important to enable all users to see each other when they were generating ideas. For that purpose the selected layout of the tool was a circle in which all avatars face a smaller concentric circle (see figure I.b). Purple boxes represent the ideas with the text on the lateral faces. The categories are represented by colored poles to which any avatar can move any idea.

Evaluation of the tools

The evaluative portion of this research was conducted under the umbrella of quantitative method. A survey was built to gather the opinion of participants (N=150) following the virtual meeting. The experiment consisted of six face-to-face meetings that were carried out at the company KPN in The Netherlands. Each meeting had in average 18 participants with professions from different fields, male and female, and with ages ranging from 17 to 51. Additionally, there were 15 virtual meetings with 6 participants in average from all over the world. In total, the sample size was 150 with participants from 14 different countries. The characteristics of the participants are presented in table I.

	Gender		Age*					Education*		
	Female	Male	< 25	26-35	36-45	46-55	>55	Bachelor	Master and higher	Others
Face-to-face (n=95)	11	22	21	42	25	4	0	46	27	16
Virtual (n=50)	17	37	7	14	15	6	8	7	22	21

*5 and 11 participants did not respectively answer the questions.

Table I. Characteristics of the participants in the sample.

Results

Table II. summarizes the results of impact of space on the business processes supported by the GSS tools. Overall, the results indicate that the representation of space is good for brainstorming, idea organizing and voting. Specifically, the space provided by *SecondLife* is considered especially useful for voting. Participants of the virtual meetings were more positive about the tools. It matches the

personal feedback that was obtained during the virtual meetings. The participants were very receptive of the tools and expressed their interest on using them again in different fields.

Meeting setting		The three-dimensional space in Second Life is especially good for brainstorming	The three dimensional space in Second Life is especially good to organizing ideas	The three dimensional space in Second Life is especially good to voting
Face-to-face	M	3.48	3.57	4.17
	n	95	95	95
	SD	1.413	1.449	1.693
Virtual	M	5.45	5.19	5.89
	n	53	53	53
	SD	1.353	1.388	1.296
Total	M	4.19	4.15	4.78
	N	148	148	148
	SD	1.680	1.622	1.763

Table II. Summary of impact of space on the business processes supported by GSS tools

Conclusions

Sub-question 1 about the implementation of applications inside a virtual world can be answered from an engineering point of view. Despite all the limitations that *SecondLife* and its virtual worlds peers have, it can be concluded that these platforms are feasible for developing applications as long as they are in research stages. From this project it was identified a support to the visualization of the parallel contribution in meetings as well as for visualization of the process. The main advantages over other technologies were the ability of *sharing a view within a group* and having *an agenda embedded in the spatial layout of the virtual setting* even when the group was geographically distributed.

Sub-question 2 about experience can be answered from the results obtained with the experiment. Overall, it can be concluded that the effect of the representation of space is positive in the sense that the users found the 3D interface understandable and easy to use (mean results were higher than $m=4.4$ in the scale that ranges from 1 to 7). Similarly, the users experienced a sense of sociability inside the environment (mean equal to $m=4.47$).

For the support of brainstorming, organizing ideas and decision making, the participants found the space provided by virtual worlds specially good (mean results were higher than $m=4.15$ in the scale that ranges from 1 to 7). Furthermore when they were asked to compare the virtual tools with previous tools that they had used before for the same purposes, the mean results show values higher than $m=3.6$ in the scale from 1 to 7 indicating acceptance to some extent. Nevertheless, it is very important to point out the differences between the results obtained from the groups (i.e. virtual meetings and face-to-face meetings). From the virtual setting the feedback was more positive. This can be explained by two factors, first most people in the FTF meeting had never used *SecondLife*. The participants in the virtual meetings were more experienced in *SecondLife* and felt more familiar with the interface and thus had a better experience when using the tools. Second explanation can be found in the fact that *SecondLife* is not really developed for FTF and functionalities like audio cannot be used within the room.

Finally, this research represents the third iteration of the design-science paradigm applied to study the effects of space on GSS tools. The results obtained indicate that the development is in a good direction and that further improvements of features like the text input, avoiding visibility for anonymity, and control of actions of the users could give better results each time.

Table of Content

Abstract.....	1
Preface	3
Management Summary	5
Table of Content	9
1 Introduction	11
2 Goal and Research Design.....	13
2.1 Research Question	13
2.2 Sub-questions.....	13
2.3 Research design	13
3 Background of Group Support Systems and Collaborative Virtual Environments	17
3.1 Group Support Systems	17
3.2 Collaborative Virtual Environments	19
4 Development of the tools	23
4.1 Function and Purpose	23
4.2 Modeling and Implementation	27
4.3 Limitations of the tools and the environment.....	30
5 Evaluation of the tools	33
5.1 Design of the experiment	33
5.2 Execution of the electronic meeting process.....	33
5.3 Results and Discussion	34
5.4 Strong points of the tools	41
5.5 Implications for GSS & SecondLife	41
6 Conclusions	43
7 Future research	45
8 Reflection	47
9 References	49
10 Appendix A. SDL and MSC models of relevant parts of the tools.....	53

1 Introduction

Comprehensively supporting teams technologically, especially in global contexts, is not easy. A problem in virtual teams is lack of presence and its consequences on team performance and satisfaction. Virtual worlds offer an additional presence dimension of technological support for teams. For example, *SecondLife* [50] is a virtual environment (within which real-life experiences can be attained) that has a range of spatially-oriented support opportunities for teams including aspects of visualization through avatars and sense of presence, as well as text and audio interaction. However, little is known about the impact and implications of use of virtual worlds for group support. In its native state, *SecondLife* is particularly weak in providing structured recorded support for team activities such as brainstorming, idea organization and voting.

Group Support Systems (GSS) have historically focused on exacting the type of support that *SecondLife* lacks. There has been extensive research examining GSS application in both laboratory and field settings (e.g. [4, 5, 6, 7]). GSS application has recently focused on virtual groups (e.g., [21, 45]). Robey et al. [49] particularly deal with varied use of technology in international virtual team contexts. Kanawattanachai and Yoo [20] examine aspects of knowledge coordination. However, aspects of GSS have not extended into virtual world domains.

Group support may represent a next generation usage of virtual worlds that is required to achieve sustained usage of virtual worlds. There are indications that after a rapid early adoption by users, the sustained usage is diminishing, leading to lower attendance. The press gave a lot of attention to virtual worlds and is now taking a more critical viewpoint on virtual worlds [53]. Decision support and group decision support is a daily activity given the growth of virtual teams. If virtual worlds can support such team better, they may be able to enjoy sustained usage.

Given the spatial characteristics of virtual worlds coupled with the structured team support of GSS, it is identified an important research question as to the combined impact of spatial considerations and group support systems. To research this question design-science paradigm [41] is used. It brings together aspects of artifact development and evaluation in several iterations until a desired state is reached. In particular, three GSS tools in *SecondLife* were built and their use for supporting group tasks in both face-to-face and distributed contexts was systematically evaluated. This report describes that research and presents implications for both research and practice.

2 Goal and Research Design

2.1 Research Question

How can space provided by virtual worlds affect group support systems?

2.2 Sub-questions

1. How can GSS applications be implemented inside a virtual world?

Previous authors of GSS literature suggested that virtual reality (VR) extensions can be applied to collaborative interfaces of GSS [5]. Because few projects were found about the application of virtual worlds to electronic meetings (e.g. [16, 58]) it is desired to study their possibilities and advantages from an engineering perspective.

Specifically, it is desired to see how the interface can be designed in order to support *the visualization of the parallel contribution* and *visualization of the process*. Some previous works are described in [16], [58] and [59].

2. How do people experience the characteristics of virtual worlds that can influence GSS?

As Qvortrup defines it, virtual worlds are computerized interfaces using 3D environments as their basic metaphor [13]. In such environments the concept of space is re-created giving the ability of being present in interaction terms despite the geographic distance. These capabilities of virtual worlds for representing space allow the users to experiment focus immersion and temporal dissociation [19] which have been found to have an impact on interpersonal conflicts and performance on a team. These aspects of virtual worlds can influence the efficiency and usability of GSS tools which explains the project focus on studying the experience of such tools through field research.

Particularly, it is desired to see to what extent the users consider the 3D interface easy to use and understandable. Similarly, from the literature review it was found that GSS can have a risk of depersonalization by the electronic medium [12] and that is why it is desired to see if a 3D interface increases the sociability of GSS tools. Additionally, it is investigated whether the users think that space provided by virtual worlds helps brainstorming, idea organizing and decision making.

2.3 Research design

This project follows the design-science paradigm which addresses research through the building and evaluation of artifacts designed to meet an identified business need [41]. Such paradigm involves a loop of building and evaluating which is iterated several times until an artifact is produced (see figure 2.1).

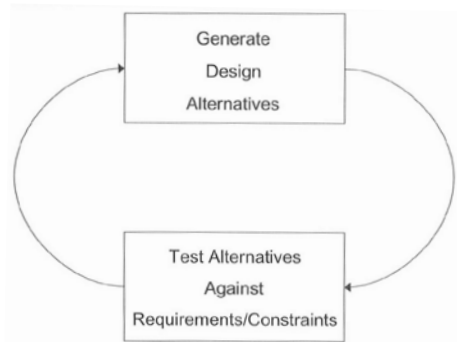

Figure 2.1. The Generate/Test cycle of the design-science paradigm [41].

Hevner et al. stated 7 guidelines for developing research using this paradigm (see Table 2.1). These guidelines are derived from the elemental idea that ‘knowledge and understanding of a design problem and its solution are acquired in the building and application of an artifact’ [41].

Applying guidelines 1 and 2, the first step was to develop qualitative and quantitative applications for GSS making extensive use of the spatiality available inside *SecondLife*. The aim was to create applications that allowed studying the impact of space on Electronic Meeting Systems. For the quantitative tool, it was required a manner of supporting voting processes in electronic meetings using space. The same tool had as a requirement to enable multi-criteria analysis of the voting sessions. In the case of the qualitative tool, it had to support brainstorming and organization of ideas also applying the concept of space.

Subsequently, following guideline 3, a field research was conducted with two main approaches: face-to-face meetings and virtual distributed meetings. The aim was to gather a significant amount of feedback about the utilization of the tools (around 150 participants). For this purpose a survey was designed to get feedback from the users after the meetings.

For the guideline 4, after analyzing the feedback obtained from the users it was possible to clarify and verify the contributions of this project to the research on GSS. Additionally, applying the guideline 5, the development of the tools followed a rigorous engineering approach sustained by the fundamentals and methodologies of human-computer interaction [42], 3-D user interface design [43] and Decision Support Systems design [44].

Guideline	Description
Guideline 1: Design as an Artifact	Design-science research must produce a viable artifact in the form of a construct, a model, a method, or an instantiation.
Guideline 2: Problem Relevance	The objective of design-science research is to develop technology-based solutions to important and relevant business problems.
Guideline 3: Design Evaluation	The utility, quality, and efficacy of a design artifact must be rigorously demonstrated via well-executed evaluation methods.
Guideline 4: Research Contributions	Effective design-science research must provide clear and verifiable contributions in the areas of the design artifact, design foundations, and/or design methodologies.
Guideline 5: Research Rigor	Design-science research relies upon the application of rigorous methods in both the construction and evaluation of the design artifact.
Guideline 6: Design as a Search Process	The search for an effective artifact requires utilizing available means to reach desired ends while satisfying laws in the problem environment.
Guideline 7: Communication of Research	Design-science research must be presented effectively both to technology-oriented as well as management-oriented audiences.

Table 2.1. Design-Science Research Guidelines [41].

For guideline 6, the project represents an iteration of the build/test cycle. It is expected that the tools will be developed further in future projects taking into accounts the results obtained from the current research.

Finally, guideline 7 is applied by presenting effectively the results to a technology-oriented audience in the Eindhoven University of Technology and in conference proceedings as well as for a management-oriented audience from the companies KPN and MeetingSupport.

3 Background of Group Support Systems and Collaborative Virtual Environments

3.1 Group Support Systems

Working in a group is not an easy task. Several difficulties have to be faced when a group of people need to approach a specific problem and have the purpose of agreeing on a solution. Many things can go wrong. Some people can have hidden agendas, may lack of focus or fail to understand their goals. Furthermore, misunderstandings can occur due to different interpretations of language, gesture, or expression [1].

In addition to being difficult, teamwork is expensive. According to Panko [2] a meeting of several managers may cost upwards of \$1000 per hour in salary costs alone. This value becomes a problem when multiplied by the overwhelming amount of meetings held by companies (e.g. more than 11 million formal meetings per day in the United States).

Nevertheless, the difficulties mentioned are not excuses to leave team work aside. Working in groups is still necessary for companies and people must collaborate to find solutions. In fact, due to the globalization effect, collaboration and communication are essential activities in which ubiquitous computing has an effect.

These activities are covered by CSCW (computer supported cooperative work) which is defined as 'computer-assisted coordinated activity such as communication and problem solving carried out by a group of collaborating individuals' [3]. Usually, these activities are supported by multi-user software applications denominated groupware (e.g. e-mail and desktop conferencing). Specifically, if the application is focused to facilitate decision making in groups, instead of the communication per se, it is denominated group decision support system or group support system (GSS) [4, 5]. In other words, CSCW are the communication and problem solving activities realized by a group using a set of computers. The software applications used for this activities are denominated groupware and within that groupware GSS is the set of applications used for brainstorming and decision making.

Nunamaker et al. [5] locate the GSS in a groupware grid in which three different levels of group work are present in the vertical axis and three different cognitive processes in the horizontal axis (see figure 3.1). The horizontal axis addresses the potential for technology to reduce the cognitive costs of joint effort. The vertical axis represents the kind of effort that can exist in a group, going from individual and uncoordinated to a more concerted and group dynamic one. Even though there is groupware presenting advantages for each cell of the grid, Nunamaker et al. focused on groupware that is located at the Group Dynamics level in the vertical axis. Is at this level in which the Group Support Systems (GSS) are located.

		Productivity Processes			GSS
		Communication	Thought	Info Access	
Group Dynamics Level		Anonymity Parallel Contribution	Structured and Focused Processes	Session Transcripts, Automatic Concept Classification	
Coordination Level		Asynchronous Communication	Schedule Matching Automated Workflow Project Management	Shared Data Stores	
Individual Level		Preparing Communication Stimuli	Modelling Simulation	Info Filtering Local Data Stores	

Figure 3.1. Groupware grid. Each cell contains examples of the kind of support available for a particular process at a particular level of work [5]. GSS is located at the Group Dynamics Level.

They found that GSS offer a great deal of support for communication, deliberation, and information access. The parallel input and anonymity, possible with GSS, improve communication interventions during a concerted effort. Also, the deliberation process is supported; some examples are the brainstorming tools, idea organizers, electronic voting, and multi-criteria evaluation. The last productivity process of the grid that is benefited from GSS is information access. This is supported by providing rapid access to the information in the minds of teammates or by providing permanent transcripts of past electronic interactions [5].

The success of GSS supporting organizational co-ordination and interaction has been proved in several occasions. One example is the Hong Kong Net project [6] in which the researchers found that GSS supported efficient group problem solving, development of new-shared meaning and cultural attitude changes.

GSS application has recently focused on virtual groups (e.g., [45, 46, 21]). Piccoli and Ives [47] examine aspects of trust and the unintended effects of behavior control in virtual teams with US participants, and note the sensitive nature of degree of control in affecting team interactions. Griffith et al. [48] point to difficulties inherent in balancing distribution and transfer of individual and organizational knowledge in virtual teams. Robey et al. [49] particularly deal with varied use of technology in international virtual team contexts. Kanawattanachai and Yoo [20] examine aspects of knowledge coordination.

Despite the advantages found using GSS there are some drawbacks that are cause of current research. Indeed, not all the meetings implementing GSS are successful. It was found that some meetings failed due not to the system itself but to the way it is used [7]. The problems arose from several sources, that is to say: process design, goals, technology, participants and facilitator. In the same way, for the specific use of GSS in brainstorming sessions (EBS, electronic brainstorming systems) some difficulties have been found regarding the quality of ideas. It was found that participants working in computer-mediated teams performed better at the divergent aspect of the tasks, recommending a greater number of ideas, while participants working face to face performed better at the convergent aspect of the tasks, proposing a lower percentage of irrelevant recommendations [8].

Furthermore, some bad points have been found when using GSS as computer mediated communication. These problems are related with the group polarization phenomena, which is defined as the tendency of people to become more extreme in their thinking following group discussion [9]. In this sense people can take more extreme decisions just because they are deciding in group. As Sia et al. state, this kind of collaboration can remove visual cues reducing social presence sufficiently to

raise group polarization. In the same way anonymity might also reduce social presence raising group polarization [39].

Additionally, capitalizing on knowledge obtained by using GSS represents a problem when automatic support is not used [10] and that is why approaches including automatic concept classification have been developed [11].

Finally, and more critically, Talbott [12] states that GSS can have a potential for depersonalization by the electronic medium together with the necessarily limited view offered at any one time by a video display screen. Talbott says that even though the authors of GSS systems know these limitations they have not proposed solutions. It is precisely where an opportunity for improvement is identified. This research aims to determine if some solutions proposed are valid and useful.

3.2 Collaborative Virtual Environments

In the previous section it was found that GSS could show drawbacks regarding depersonalization and limited view offered to users. The current study presents an approach to overcome these difficulties by using the concept of space in virtual worlds. In this section the capabilities of virtual worlds for facilitating focus immersion, as well as other dimensions of cognitive absorption, are described. In the same way, the advantages and disadvantages of using virtual worlds for collaboration are stated showing specific examples.

As Qvortrup defines it, virtual worlds are computerized interfaces using 3D environments as their basic metaphor [13]. In such environments the concept of space is re-created giving the ability of being present in interaction terms despite the geographic distance. The human beings are represented by means of avatars that can interact with several types of objects that can be animated or static [14, 15]. Furthermore, these environments do not necessarily follow similar rules to that of the real world [16]. In this sense, new capabilities are offered obtaining a concept called 'enhanced' or 'augmented' reality.

Regarding the concept of space, in virtual worlds the basic space experience is simulated by means of virtual reality techniques (i.e. passive stereo, active stereo and interaction devices). Thus, the perception of space and reality depends on the implementation of the techniques used [17]. Moreover, this perception is affected by the function of the virtual world; there can be applications aimed to behave in the same way as the phenomena in the real world (i.e. iconic function), others have the purpose of being input-output devices for different applications (i.e. indexical function), and finally there are virtual worlds that operate based on their own dynamic laws (i.e. symbolic function) [13].

Additionally, the capabilities of virtual worlds for representing space allow the users to experiment focus immersion [18] which has been found to have an impact on interpersonal conflicts and performance on a team [19]. Specifically, Rutkowski et al. [19] found that virtual teams with aggregated higher levels of focus immersion and temporal dissociation (dimensions of cognitive absorption) demonstrated higher levels of performance and interpersonal conflict. Similarly, they found that teams with aggregated high levels of focus immersion and aggregated low levels of temporal dissociation demonstrated the best performance and lowest levels of interpersonal conflicts. In this way, virtual worlds, as examples of ICT applications, can be useful in the managerial field with the purpose of improving team performance and reducing interpersonal conflict. Rutkowski et al. also found that individuals with high levels of focus immersion preferred asynchronous communication

media, while on the contrary individuals with low levels of temporal dissociation preferred synchronous media.

The effects of virtuality, not necessarily by means of 3D environments but via ICT applications, have been assessed in several occasions (e.g. [19, 20, 21, 22]). In this context, the term virtuality refers to the conditions under which a virtual team works, defining virtual team as a group of people geographically distant. In the case of team performance, Lu et al. [21] found that several practices related with ICT applications produced considerable negative influence on some aspects. Such aspects included ability to meet commitments and complete projects on time besides communication and trust in team members. What is even more interesting is that they found no impact of geographic distribution of team members on team performance. The problem identified about ICTs is that team members faced difficulty in managing the overhead generated from the use of multiple systems, across multiple teams, with different norms and practices. Additionally, Kanawattanachai et al. [20] found that transactive memory systems (TMS) can be formed even in virtual team environments where interactions take place solely through electronic media. These TMS are important constructions for the team performance based on the idea that individual members can serve as external memory aids to each other.

Additionally, virtual worlds have been studied for their impact on collaboration. Benford et al. [23] introduced collaborative virtual environments as groupware for supporting CSCW activities. According to the CSCW supporters, the collaborative virtual environments (CVEs) represent a technology that enables interaction in different ways to that offered by videoconferencing or audio [23, 24, 18]. The simulation of physical space becomes a valuable resource for negotiating social interaction, promoting peripheral awareness and sharing tools [25, 26]. Similarly, CVEs offer the ability to support online situations in which large amounts of users interact (e.g. trading floors or a congress). Additionally, CVEs allow the users to manipulate shared 3D models and discuss about them showing their own point of view and indicating where they are looking at [23, 24]. Moreover, as Churchill et al. state it, “CVEs can provide support for synchronous activities, unlike e-mail and bulletin boards, and can provide real time support for the sharing of visual artifacts unlike telephone conferencing facilities” [24]. In addition, CVEs give the possibility of interacting asynchronously by leaving information inside the virtual world that can be retrieved posteriorly. Another remarkable capability of CVEs is scalability. CVEs have the potential to support as many users as desired because the designers can use as much 3D space as required [24].

In addition to the capabilities mentioned above, several authors have found that the characterization of participants by mean of avatars offers a more natural way of interaction compared to other applications supporting CSCW activities [27, 28, 29]. For example, Bowers et al. [30] found that avatars, embodiments of the participants, do have a social interactional role and are not used just to indicate the view that a participant has of the virtual world. Furthermore, they found that avatars sought to engage a face to face interaction when they were talking to each other. They also found that the quality of representation of human gestures, for body and face, can diminish the effect of communication and they suggest that CVEs have to take into account seriously this aspect.

The capabilities already mentioned have also been identified in other studies that apply CVEs for some specific fields (e.g. product development and conceptual learning) [31, 32]. In the latter case the authors found that for CVEs to have an effective communication function it is necessary to consider the nature of the communication that is useful to the users [31]. They also found that participants did not exploit the full range of multimodal communication, that is to say, there were preferences for using visual-textual interaction instead of auditory. For the product development case, Bochenek et al.

[32] found that CVEs offer to product development teams an expanded and improved capability for creating realistic simulated models.

Another aspect of CVEs is the ability for improving the characteristics of physical interaction [33, 27, 28]. This concept is called augmented reality and can be applied to create intuitive 3D interfaces for CSCW activities [33]. In this way participants can hold a video conference session with superimposed objects on it maintaining a more natural interaction because, unlike other technologies, the groupware support can rely on standard social protocols. What is even more interesting about this concept is that users can share imagined possible situations of the topic of discussion [34, 35].

All these capabilities are present in virtual worlds like “*SecondLife*” [50] or “*There*” [61] and that is why big companies like IBM, Intel and the US army do believe in such environments and are investing heavily on them [22]. To the date, several companies have a presence in this kind of worlds and the amount of users is increasing each year. Nevertheless, much of the company presence is for marketing and learning purposes. An example is the initiative called NMC campus [36] which aims to study and understand the application of virtual worlds (e.g. *SecondLife*) as groupware. An interesting fact about the NMC project is that it involves almost 200 organizations, most of them universities from USA.

Indeed, virtual worlds are becoming popular in universities and companies as a tool for creating virtual learning environments. *SecondLife* for instance is attracting more and more interest from educational and business fields. *SecondLife* is an online virtual world where the content is built and owned by its users, providing tools and guidance for manipulating the environment and allowing action scripting, object construction and an economy that supports the creation of virtual environments [51]. *SecondLife* has characteristics both as a distributed communication tool and as an entertainment environment, and has relevance in both online collaborative learning and online business fields.

In this environment real-life organizational experiences can be attained. It is an opportunity space (not a deterministic space) limited only by imagination. Admission is free and learning opportunities abound. *SecondLife* has representations of a wide variety of existing global organizations (e.g., car dealerships, computer industry, insurance companies and financial institutions), in addition to newly created entrepreneurship whose only limitation is the imagination of the creators. Governments also have a presence on *SecondLife* (e.g., the Swedish embassy). *SecondLife* has a currency (i.e., Linden dollars) that enables participants to engage in business transactions. There are currently over 30 universities with a *SecondLife* presence and communities of practice.

Unfortunately, *SecondLife* currently has little in terms of structured support for groups in problem solving contexts. This is not particularly surprising, given its relative youth and initial entertainment focus. The Internet was similarly initially under-developed and lacked real business applications in the early 1990's. Over the years, however, the Internet has matured and provided support for a wide variety of business applications e.g., electronic commerce as well as aspects of group support (e.g., Romano et al. [52]). Virtual worlds also need to facilitate real work. After the initial hype there is now extended expectation. Getting real world work done can help to increase acceptance and establish continued usage.

The Alpine Executive Center [37], located on the MeetingSupport island in *SecondLife* has been developed with group support in mind. Within an alpine ski village, surrounded by snow-covered mountains and tucked away deep inside the mountain, lies an advanced meeting facility where real-

world activities take place in a virtual environment. A main amphitheater is accessed via a train that goes deep inside the mountain complex or by a walk along the frozen ice skating pond, or by teleport from the visitor landing area. An auditorium supports large groups in plenum for presentations and moderated discussions. A host of additional facilities exist to support groups. For example, groups can meet at one of the ten gathering spots around the Alpine village, including mountain huts with interactive screens and scenic lookouts. Participants also have opportunities to explore, shop, play, go ice skating or just have fun together riding the chair lift and using the timed downhill and slalom ski runs. Other projects inside *SecondLife* that have the purpose of supporting collaboration in groups are DSS [38] and the work carried on by Drew Harry at the MIT [16] in which the concept of space is used to support decision making.

4 Development of the tools

4.1 Function and Purpose

The aim was to create three applications that allowed studying the impact of space on Group Support Systems: a quantitative tool for supporting voting processes, a qualitative tool for brainstorming and a qualitative tool for organization of ideas (these last two were combined in a bigger qualitative tool). The goal was not to replicate existing GSS but to see how the notion of space could be exploited. For developing these applications a design process was followed. Such process was based on rules for designing DSS user interface design [44], virtual environments usage protocols [42] and 3-D user interfaces design [43].

As Dan Power describes it, the software interface between the computer application and the user could determine the efficiency of the decision support system [44]. He proposes some guidelines derived heuristically from his previous experience and from other author's research:

- Strive for consistency in sequences of actions.
- Reduce information load.
- Create an aesthetic and minimalist interface.
- Provide informative feedback about system status.
- Design interaction to create closure.
- Anticipate and avoid errors.
- Permit easy reversal of user actions.
- Support internal locus of control of users.
- Provide accelerators for frequent users.
- Provide help capabilities and documentation.

Similarly, Bowman et al. suggest the use of “magic” interfaces in place of “natural” ones when tasks require productivity and efficiency [43]. They also point out the importance of guiding the user by providing physical or virtual constraints while designing 3-D interfaces. In the same way, Stanney [42] gives some protocols for usage of virtual environments in order to avoid “cybersickness” and diminishing quality in the input from the user. The author goes on to say that an exposure duration and inter-session interval should be set for retaining the attention of the user.

Following the mentioned guidelines, it was possible to develop a tool that used 2 spatial dimensions for multi-criteria voting and analysis. It was called the *VotingFloor*. The avatar representation of each person inside *SecondLife* has several properties that could be used for interaction. One of these was the relative position respect to an object. This characteristic matched a natural way of giving a numerical answer to a closed question. For these kinds of purposes, software tools usually use slider bars or numerical fields (e.g. “*What is the impact of alternative one in the schedule of the project? Please give an answer in the range 0 –low to 10 –high*”). The idea was to use a voting platform on a floor the size of 10 meters x 10 meters. The platform was set up in a 10 x 10 grid on both the X and Y axis. Both axes could be labeled with two criteria. To vote on an issue each avatar positioned itself on the grid where they felt the two criteria met. The tool had to detect the position of each avatar on the grid and compute the x/y coordinates on a 10-point scale for both axes. At the same time the tool combined and averaged the coordinates of all the avatar's positions on both axes. Another important characteristic was to display on a wall mounted object the average location of the whole group of avatars that were standing on the grid. Finally, the tool had to allow for saving the results of the vote,

in a way that could be included in a summary report. A picture of the multi-criteria vote tool is shown in figure 4.1.

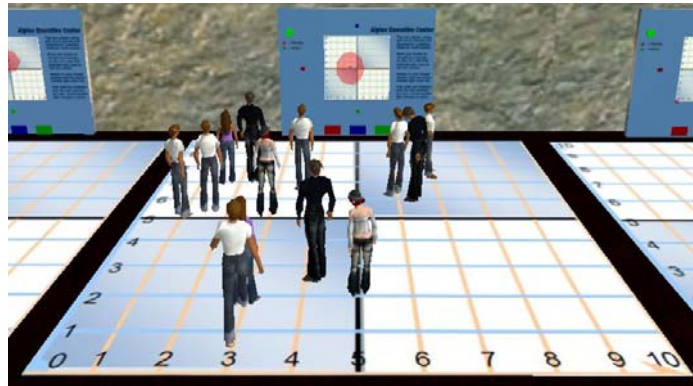

Figure 4.1. Multi-criteria voting platform inside *SecondLife*.

In figure 4.1 13 avatars are voting on a specific issue that has two criteria. Each avatar stands where he/she thinks the issue scores on those criteria. Behind the platform there is a board that mimics the grid in a lower scale. It is used for representing the average and standard deviation of votes of the group of avatars. These measures are displayed by using a blue ball for the average and a red ball for the standard deviation. The red ball has the ability of changing its shape according to the level of the standard deviation. A large standard deviation of votes in a criterion is represented by a red ball with bigger size in that dimension (see figure 4.2).

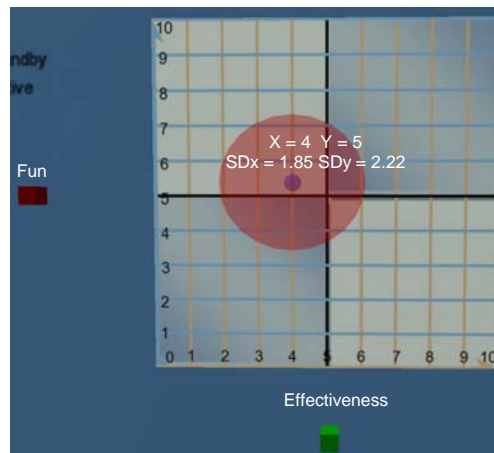

Figure 4.2. Board for displaying the average (blue ball) and standard deviation (red ball) of votes in two dimensions.

Both parameters are calculated in real-time enabling the participants to see the decision of the group as soon as they move. Additional characteristics are registering of votes of a specific session into a database and reviewing of previous sessions by opening a webpage in a web browser. Furthermore, because any avatar can walk around in the MeetingSupport island, the starting of a voting session is restricted by an authorization algorithm that uses a list of avatars with enough access rights. In the same way, another list is used to select the avatars that can vote. More specific details about the tool will be given in the implementation section.

The qualitative tool was developed with the purpose of supporting brainstorming and organization of ideas. It was called the *IdeaGenerator*. The development of this tool was a challenge because the nature of these processes involved a higher coupling of activities like sending/receiving messages and moving objects. Furthermore, the tool had to support these activities for all the avatars at the same time and in any order. The main idea about the tool was to give the feeling of working in a group in which each individual action has a particular effect on the main results. Thus, it was important to enable all users to see each other when they were generating ideas. For that purpose the selected layout of the tool was a circle in which all avatars faced a smaller concentric circle (see figure 4.3).

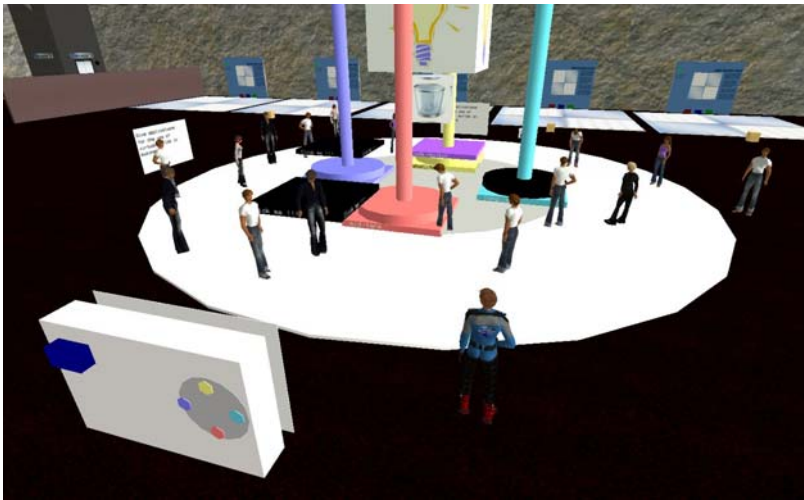

Figure 4.3. Group of avatars standing inside the circle of the tool for brainstorming.

Similarly, it was required a way of representing an idea introduced by users. This representation had to display the typed text in several faces in such a way that all avatars were able to see the text from their point of view. Therefore, a box representation with text in all its lateral faces was selected (see figure 4.4).

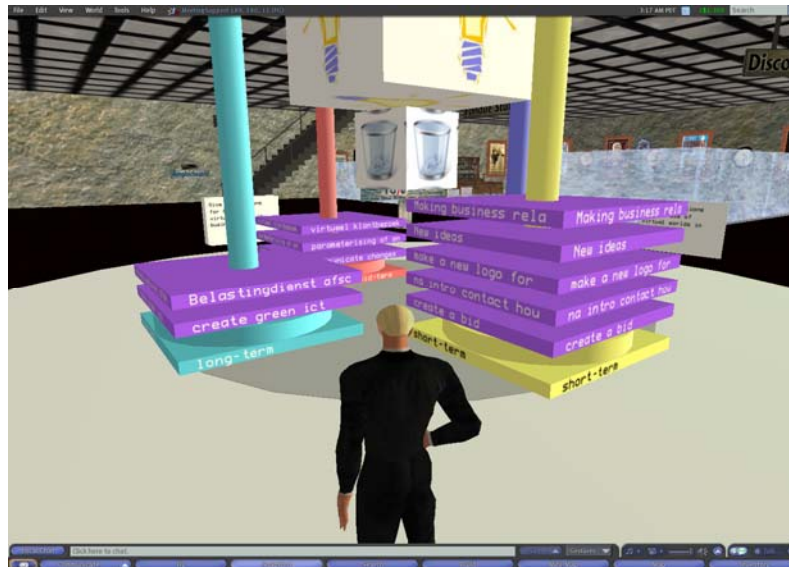

Figure 4.4. Ideas represented by purple boxes with text in all their lateral faces.

The inner circle has 4 categories in which the generated ideas can be classified. Each category has a different color and is being represented by a pole that stacks all ideas that the participants consider it should have. Additionally, these categories are composed by a base showing its name. At the middle of the tool two boxes are located. The first one is the light bulb which has the function of creating ideas when it is touched by an avatar. The other one is the trashcan which is used when an avatar considers that an idea should be deleted. For an avatar to create an idea he/she should make a click on the light bulb, immediately a new idea appears surrounding the avatar. Then the avatar can make a click on the idea putting it in edit mode. In this mode the idea becomes black giving the feedback to the user that it is being edited. Furthermore, the avatar can introduce a label to be displayed on the faces of the idea (i.e. a short text that identifies the idea from others) and a larger text explaining the idea thoroughly. While the idea is in editing mode the avatar can make a click on any of the four poles and the idea will move to that category taking the highest position available (see figure 4.5).

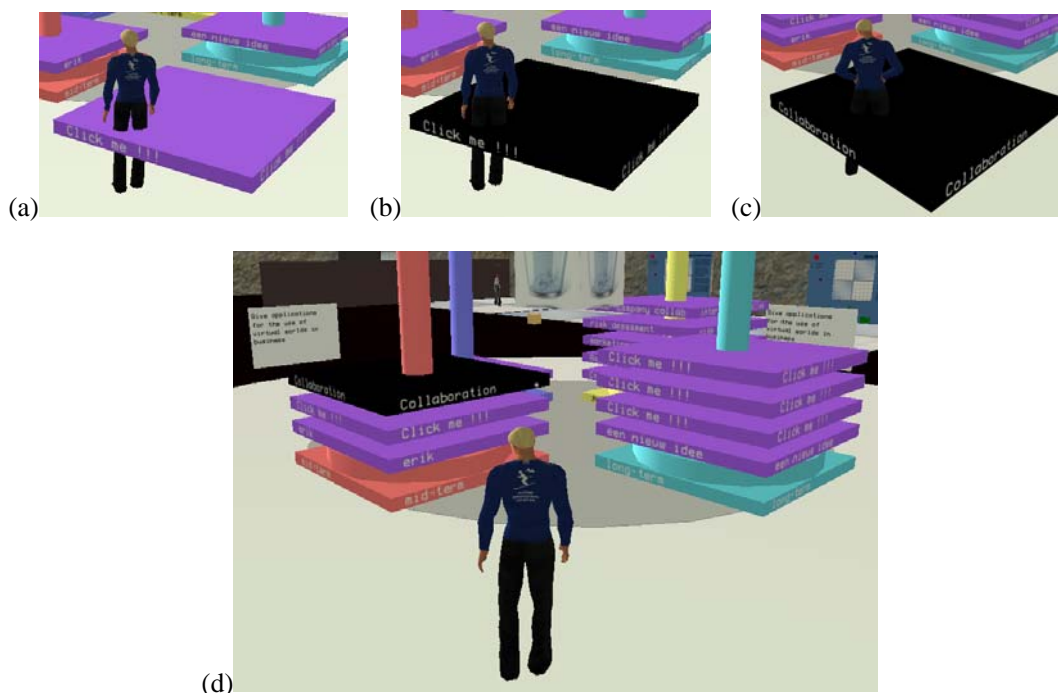

Figure 4.5. Avatar creating (a), editing (b, c) and positioning (d) an idea.

Other parts of this tool are the control board and the display boards. The control board is used by the facilitator for starting and stopping a session as well as for introducing the names of the categories. The display boards are used for showing indications that help the participants to brainstorm about a specific issue. Another feature is the capability of showing to the group a spatial agenda of the process that would be followed. The process followed for the purpose of the research included a brainstorming session from which 5 different issues were taken for having a voting session on each one. In figure 4.6 it can be seen the spatial distribution of the meeting. In this way the participants know at any time the steps of the process and can identify a logical sequence.

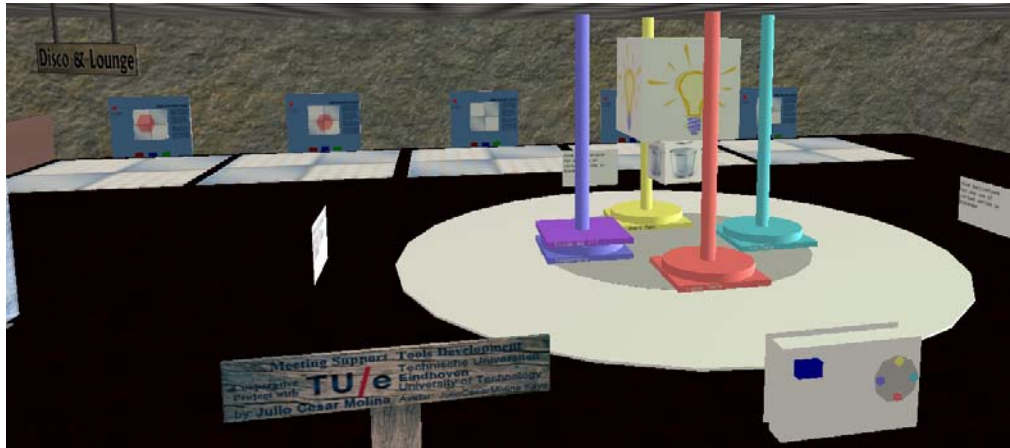

Figure 4.6. Spatial distribution of the tools. This distribution gives an idea of the meeting's agenda.

As it can be seen in the previous figures, the development of the tools carefully took into consideration the guidelines mentioned at the beginning of this chapter. Both tools make an extensive use of the concept of space available inside *SecondLife* and are intended to give an intuitive interface to the user. Keeping the input methods as simple as possible, reducing the information overload, providing feedback about system status, following closed sequences of interaction and allowing reversal of users' actions are present in the *IdeaGenerator* and *VotingFloor*. Virtual constraints for guiding the user are present as well.

Furthermore, it was important to clarify the mental processes that the users had to perform when using the tools. To brainstorm ideas and classify them is more demanding than just voting on an issue presented to them. That is why the *IdeaGenerator* required more actions from the user and resulted in a less intuitive and more complicated tool than the *VotingFloor*. In fact, with the *IdeaGenerator* the avatar needed to create the idea, put a label that identified it, add a detailed description, organized it in a category, walk around and look to the other ideas. In the *VotingFloor* the avatar just needed to move to the position that was desired.

4.2 Modeling and Implementation

SecondLife is a platform that allows the users to create objects and program their behavior. The programming part is implemented through scripts that can be contained inside the objects. An object can contain several scripts that run concurrently. This parallel processing is implemented by a farm of servers who give a slot of time to any script of an object located in an island. The communication between objects is realized through channels. If an object wants to react to a specific command it can listen to the channel through which the message was sent, either by an avatar or by another object. Furthermore, the objects respond to physic rules like inertia, gravity, force, and energy. Using these concepts and the associated functions, natural interfaces can be developed allowing the user for having a more intuitive interaction.

The tools are composed by several objects in the structural part. Usually, these objects are linked together so they can be treated as a group and moved to other locations. Also, objects in a group share characteristics like accessibility to other avatars and whether they are phantom or not.

For programming the scripts *Linden Labs* developed their own language called *LSL* (Linden Scripting Language). It contains around 400 preprogrammed functions divided in categories like communication, movement, detection, textures and list manipulation. This is a rich knowledge base that is well documented and includes application examples.

The main way of coding the scripts is using the environment that is provided in-world. It has a helpful syntax coloring feature and pop-up windows showing the description of the function over which the cursor is located. Another possibility is the use of external editors that are able to interact with the *SecondLife* grid (i.e. farm of servers) which is very useful for testing individual scripts without running the whole client of *SecondLife*. Nevertheless, the environment has some limitations for coding. Because of the concurrency nature of the programming, often it is required to see the codes of different scripts, inside different objects, at the same time. It implies editing the characteristics of 2 or 3 objects simultaneously as well as opening 2 or 3 coding windows which becomes quite confusing and prone to errors.

Due to the parallelism and distributed computing of the platform a way of modeling the tools for giving insight to their structure and interaction was required. The structural description allows for having an abstraction and knowing modules of the tools. *SDL* (specification, description language) [57] was used for this description. Similarly, the behavioral representation provides an intuitive way for seeing the interaction. It was developed using *MSC* (message, sequence charts) [57]. The reason for using these two languages instead of PetriNets or UML is that they have inherent capabilities for specification of systems composed of elements that communicate with each other. Furthermore, these languages are supported by the *ITU* (International Telecommunication Union) [57].

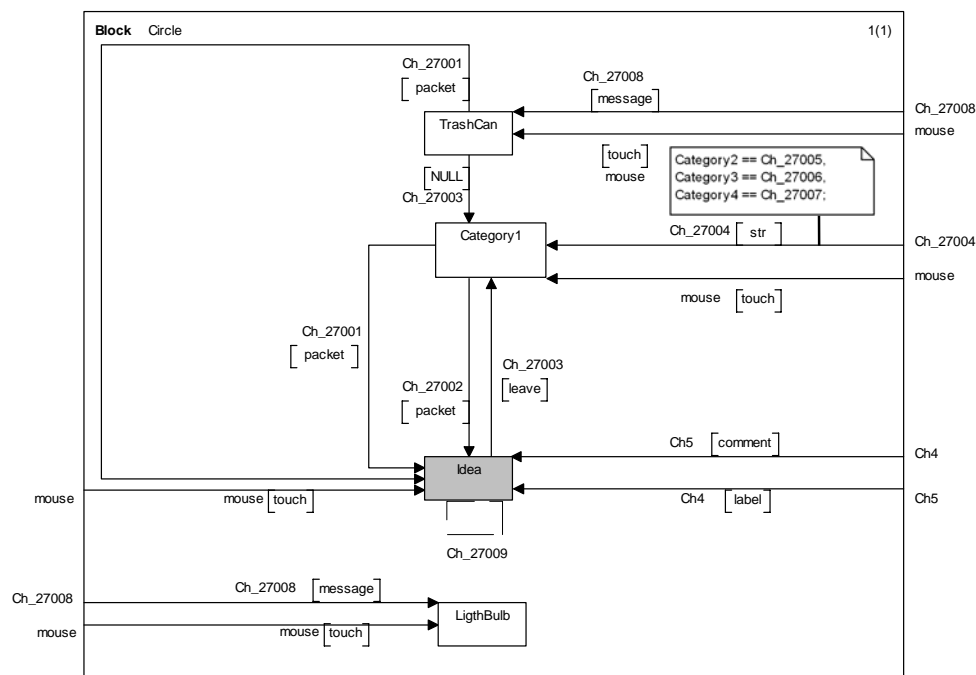

Figure 4.7. SDL model showing the main elements and channels of the *IdeaGenerator*.

In figure 4.7 the main elements of the *IdeaGenerator* are shown together with the channels that they use for communication. In this type of structural diagram the boxes represent blocks in which the system is subdivided. The arrows represent the channels used for sending the signals/messages

contained within brackets. The channel used is described by the prefix 'Ch' followed by an integer that can be negative in which case the negative symbol is '-' (i.e. Ch_27009 represents the negative channel -27009).

Specifically, this model shows 4 main subparts of the *IdeaGenerator* tool: the light bulb, the trashcan, one of the four categories and an instantiation of an idea. The external square represents the limits of the block 'Circle' which groups the mentioned parts into a single structure. Each arrow coming from outside the block represents a channel that is connected to an element. Note that a specific channel can be connected to several elements (e.g. channel -27008 is connected to the light bulb and to the trash can). This means that a message sent through a channel can be received by several subparts at the same time. In this model the element 'Idea' is shown in gray because it represents an instantiation of this class of object. An instantiation of this object can communicate to another instantiation through channel -27009. Additionally, in the model only one category is shown for the sake of simplicity because the other three categories communicate with the other elements using the same channels. Only the channel -27004 varies for the other categories. This is shown in a textual description indicating the channel used for each category.

The interaction between these elements can follow several sequences. That is why in figure 4.8 a MSC model is used for showing an example of communication. This message sequence chart shows 4 actors: an avatar and 3 processes (every process represents a script). In the chart the actors are represented by boxes with their names. Their states and actions are linked with a vertical line. The sequence in the MSC goes from the upper part of the chart to the bottom. The messages sent from one actor to another are represented with horizontal arrows going out from the sender.

Each process starts in a specific state (e.g. 'Default') and as soon as a message is received an action is fired and messages are sent to other processes. After the actions are realized a specific state is reached again.

In the MSC of figure 4.8 the sequence of starting a session is shown. An Avatar touches the SessionButton which is in state Default. This process sends a message with value TRUE to the processes Bulb-Creator and TrashCan indicating them that a session has been started. After sending the message the process returns to the Default state. When the processes Bulb-Creator and TrashCan receive the message they save the value in local variables called Session_Started which are used in further actions. Both of them return to the Default state.

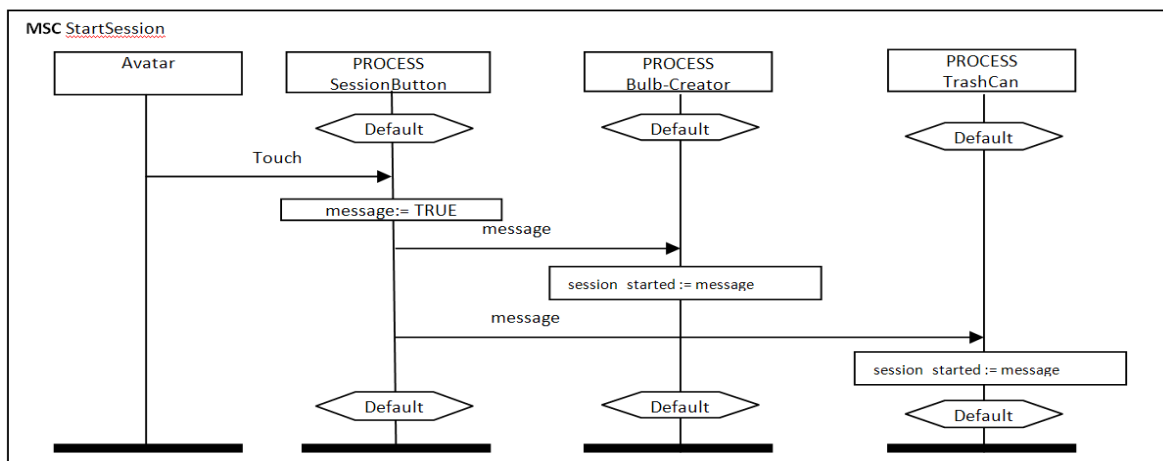

Figure 4.8. MSC of a particular sequence for the *IdeaGenerator*.

Finally, in figure 4.9, a model of the process *TextBoard* describes the functionality of a script. This model is very similar to a flow diagram and its elements match those of the higher level models previously mentioned. The complete set of models for both tools, *IdeaGenerator* and *VotingFloor*, is in Appendix A. Only the most relevant elements of both tools were modeled for the sake of simplicity.

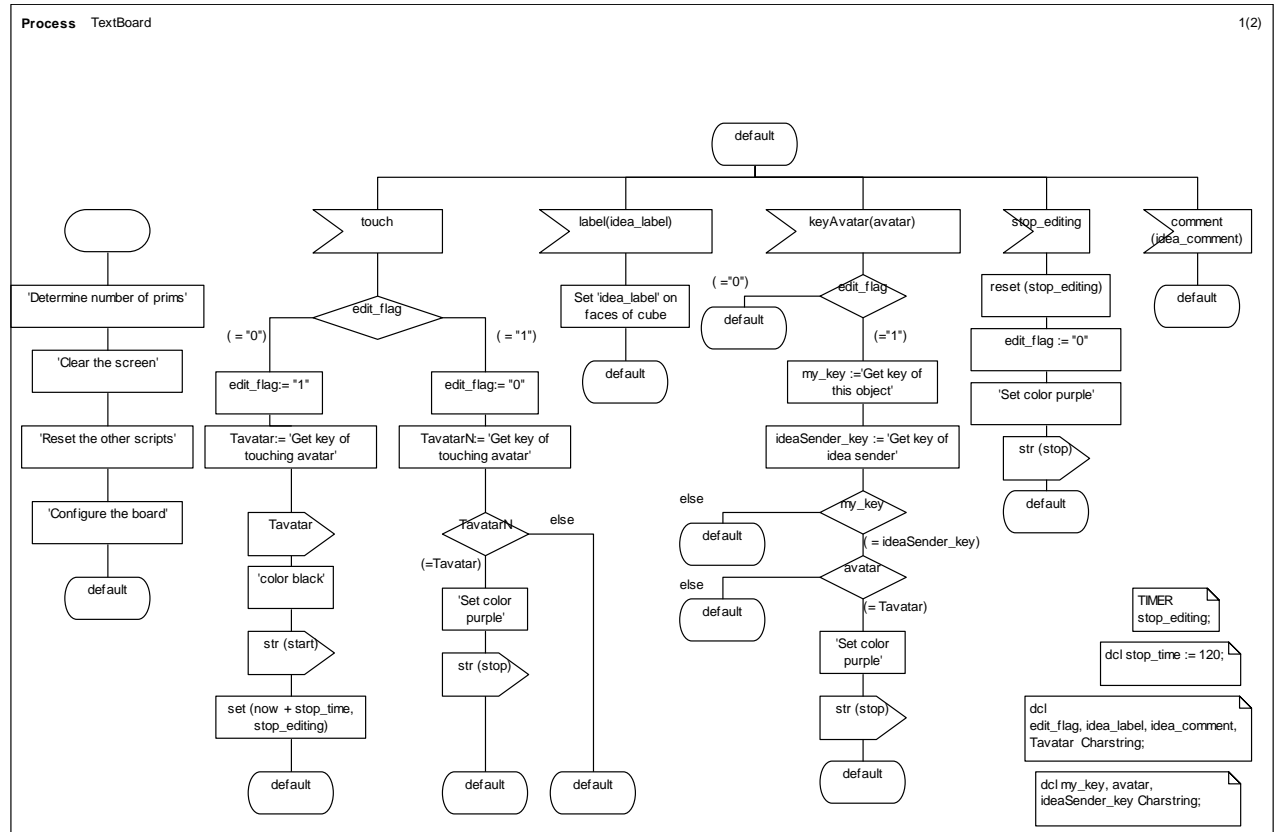

Figure 4.9. SDL model of the script controlling an idea.

4.3 Limitations of the tools and the environment

The client of *SecondLife* significantly restricts the way of interacting with text. The client was designed mainly to chat using plain text and voice over IP. Indeed, through this research few examples of applications for purposes different to chatting, gaming and displaying of pictures corresponding to web pages or slides were found inside *SecondLife*. Other tools in *SecondLife* have the same text input drawbacks of these developed in the current project (for instance see [16]). It is important to mention that these difficulties for managing text are not exclusive to *SecondLife*. Clients of virtual worlds like *Forterra* [59] or *There* [61] present similar problems.

Typing the string for indicating the client program which channel to use for introducing text into an object is unavoidable in *SecondLife*. During the trials of the tools it was realized the discomfort of the users when typing ‘/4’ before the text of the idea in the brainstorm application. It was not intuitive and prone to errors. Furthermore the users had to move their point of focus from the object representing an idea to the chat bar of the client. This increased their confusion.

Additionally, a direct support for copying and pasting in the tools is not present in the current version. This limits the options for exporting to and importing from other tools.

Another limitation is the difficulty for the facilitator to control the avatars of the participants. In a session using *GSS* tools the facilitator is able to control completely the computers that the participants are using. The facilitator can start or stop the session, move to different windows and restrict the computers to show only the *GSS* application. This control power is lost with *SecondLife*. Mostly due to the fact that the avatars are free to move, fly, touch objects, send instant messages, do gestures, and talk to anybody in any moment. During the face-to-face experiments it was necessary to ask the participants for their collaboration to focus on the aspects of the meetings. Nevertheless, some of them started to fly, did distracted gestures and the most experienced edited their avatars during the meeting. It was interesting to see that during the virtual meeting experienced users of *SecondLife* had a code of behavior and though they were in different locations they concentrated in the focus of the meeting. Additionally, the environment runs inside a client program and outside participants are able to see other windows and thus the facilitator does not have any control over their actions.

One more limitation of the tools developed compared to the *GSS* tools is a loss of anonymity. This feature of *GSS* has been studied in several occasions (e.g. [5, 8, 39]) and has been proved to be very useful for the brainstorming process. With the current status of the tools developed the anonymity is lost because the participants can determine easily which avatar is creating a specific idea and where an avatar is standing to give a vote. Furthermore, the capabilities of voice over IP help to identify who is controlling an avatar even when the avatar name doesn't match the real name of the user behind it.

5 Evaluation of the tools

5.1 Design of the experiment

The evaluative portion of this research was conducted under the umbrella of quantitative method. A survey was build to gather the opinion of participants (N=150) following the virtual meeting. The survey measured the perceived ease of use [55], the entertaining nature as well as the arousal [56] of the designed tools and their respective efficacy on social presence [54] and meeting satisfaction. The survey is part of a research project with multiple professors from around the world. The results presented here are limited to the focus of this thesis: the use of space in GSS. The description is also limited to descriptive statistics since analyzing the results of the complete survey is part of a bigger research project that this masters thesis was only one part of. The results of the survey have been used to draw recommendations to improve next design version of the tools following the design-science paradigm. The aspects of the tools analyzed in this project are:

- Ease of use
- Sociability
- Understandability
- Support of GSS processes

5.2 Execution of the electronic meeting process

For the electronic meeting process the goal was twofold: give participants an experience of what can be achieved and to collect data by means of the survey. The agenda followed during both kinds of meetings let the participants to use the tools for brainstorming, organization and multi-criteria decision making. Table 5.1 shows the process in more detail.

The process was designed to cope with the limitations of time because the participants were using their work hours. Nevertheless, the process allowed for giving an experience to the users enough to assess the characteristics of the environment as well as the tools. Note in table 5.1 that the processes studied (i.e. brainstorming, organizing ideas and multi-criteria analysis) have 10 minutes each.

Step	Time in minutes
Introduction	5
Brainstorm	10
Transition to next tool	5
Organize the ideas	10
Transition to next tool	5
Multi-criteria analysis	10
Survey	15
Total	60

Table 5.1. Process followed when using the tools.

The spatial distribution of the tools allowed for having an overview of the steps in the meeting (see figure 4.6). In the beginning the participants were given an explanation of the research project and the steps to be followed during the meeting. The total time was limited to one hour and the process was targeted at 10-15 participants. Goal was to limit the number of ideas to 50 in the whole sessions to keep it manageable. The transition times between the tools were a buffer and were needed to transfer data from one tool to the next.

For the brainstorming tool the participants were asked to give applications for the use of virtual worlds in business. There was a limit of maximum 5 ideas and they were required to describe the idea in maximum 10 words. Each new idea was stacked in the ‘Temporary Holding’ category from which the participants took each one and moved them to the other categories: ‘Short Term-Easy’ (can be implemented within a month), ‘Mid Term-More Difficult’ (longer than a month, within a year) and ‘Long Term’ (more than a year). Then, the 5 most important ideas from the short term category were evaluated on two dimensions: ‘contribution to the business’ and ‘fun’ using the decision making tool. Finally, the results of each voting session were discussed with the group.

The experiment consisted of six face-to-face meetings that were carried out at the company KPN in The Netherlands. Each meeting had in average 18 participants with professions from different fields, male and female, and with ages ranging from 17 to 51. Additionally, there were 15 virtual meetings with 6 participants in average from all over the world. In total, the sample size was 150 with participants from 14 different countries. The characteristics of the participants are presented in table 5.2.

	Gender		Age*					Education*		
	Female	Male	< 25	26-35	36-45	46-55	>55	Bachelor	Master and higher	Others
Face-to-face (n=95)	11	22	21	42	25	4	0	46	27	16
Virtual (n=50)	17	37	7	14	15	6	8	7	22	21

*5 and 11 participants did not respectively answer the questions.

Table 5.2. Characteristics of the participants in the sample.

The tools in *SecondLife* were also used for a meeting of a community called *VirtualAfrica*. This meeting had the purpose of generating ideas about the possible ways of improving the access of African people to virtual worlds. The meeting lasted for more than 1 hour and was facilitated for a leader of that group. It was very interesting to see how the tools were completely controlled by people not involved in their development. In the end of the meeting the group generated around 30 ideas organized in the categories easy, possible and difficult. A summary was sent to the involved users.

5.3 Results and Discussion

Figures 5.1. show the results of the complexity that the participants experienced. The scale used was from Strongly Disagree (1) to Strongly Agree (7). In almost all figures the mean is higher than $m=4$ indicating that in average the group found the tools and *SecondLife* easy to use and understandable. Similarly, all figures show a normal distribution shape but with right skewness indicating higher levels of ease of use and understandability. Particularly, figures 5.1.a. and 5.1.b. show that using the brainstorming tool was easy and understandable. The ease of use of the *VotingFloor* in figure 5.1.c,

with a mean of $m=5.35$, was high as well. Figure 5.1.d confirms the understandability of this tool showing a mean of $m=5.26$.

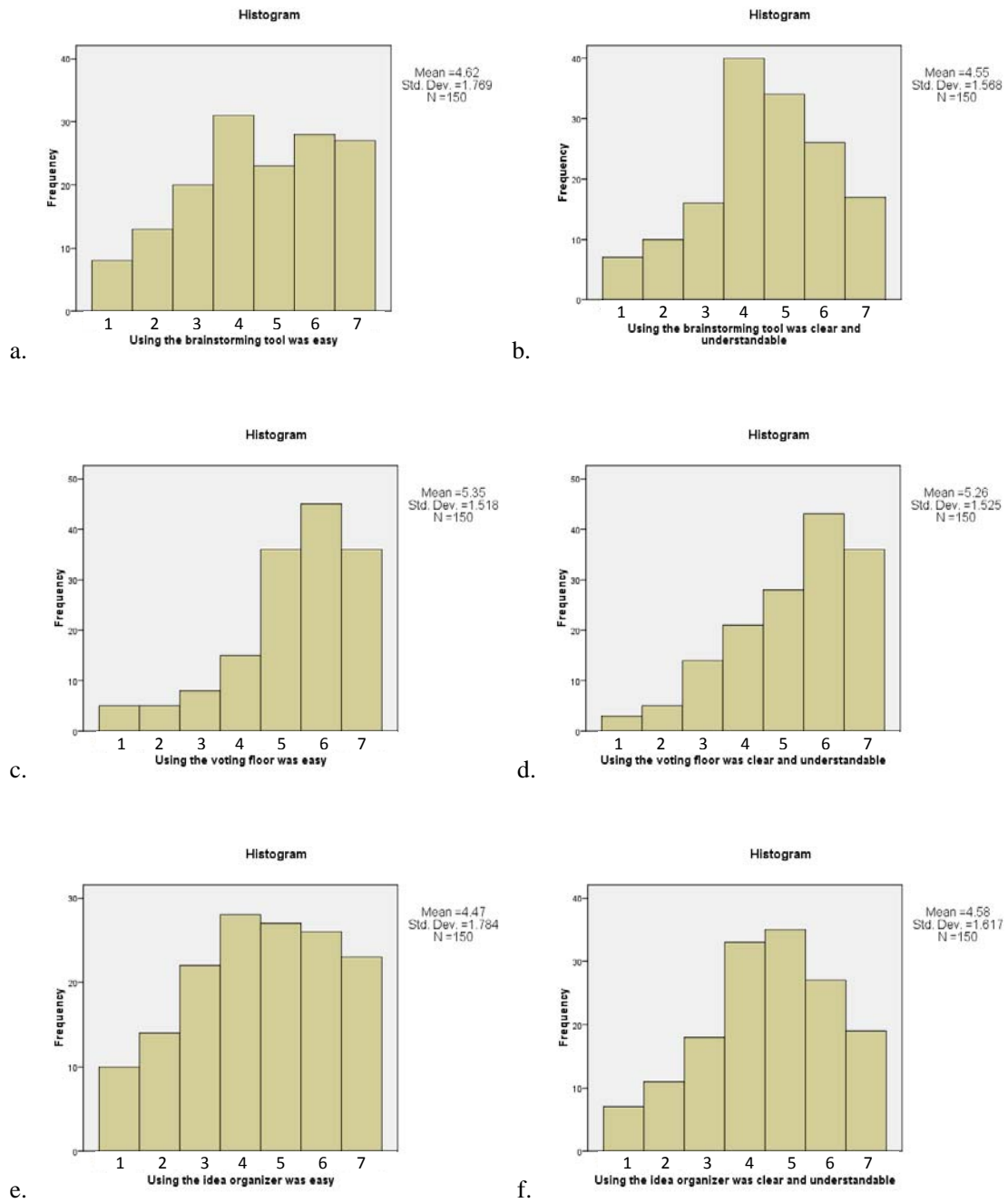

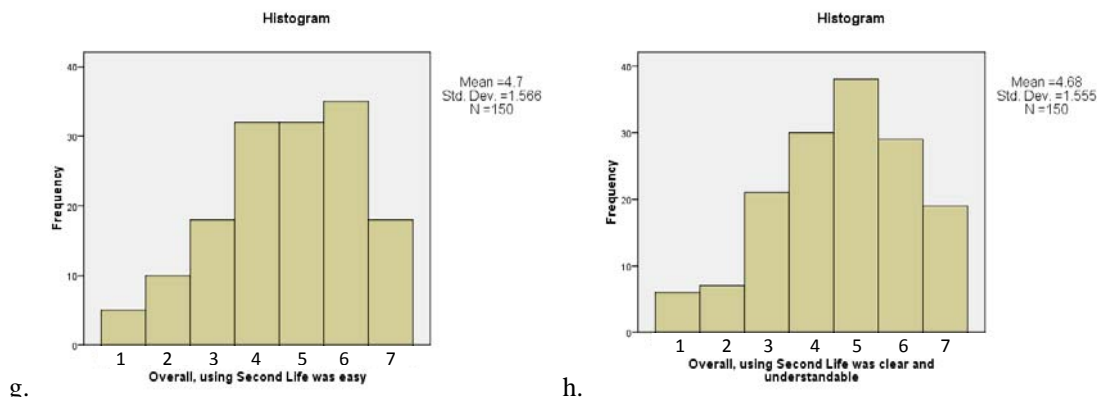

Figure 5.1. Results of ease of use & understandability of both, the tools & SL.

Figures 5.1.e and 5.1.f also show that the idea organizer (embedded in the same *IdeaGenerator*) was the least intuitive tool (levels of ease of use of $m=4.47$ and understandability of $m=4.58$). These results are consistent with the behavior of the participants during the meetings in which it was possible to see the difficulties introducing text to the ideas due to the sequence of touching the idea to start editing it, typing ‘¼ text of the idea’, touching a category and finally touching the idea again to stop.

Respect to *SecondLife* in general, figures 5.1.g and 5.1.h show that it is easy to use the technology ($m=4.7$) and understandable ($m=4.68$).

The results shown in the previous figures are summarized in table 5.3. In this table mean score for ease of use are significantly more positive in the virtual meeting setting. Comparing the results of each tool, the means indicate that the voting floor was rated as the easiest to use ($m=5.3$, $SD=1.4$), then equally the brainstorming tool ($m= 4.6$, $SD=1.57$) and the idea organizer ($m=4,54$, $SD=1.58$).

Meeting setting		Brainstorming tool	Idea organizer	Voting floor
Face-to-face	M	3.9731	3.9185	4.9840
	n	93	92	94
	SD	1.45842	1.50690	1.48007
Virtual	M	5.6731	5.6250	5.8558
	n	52	52	52
	SD	1.10207	1.02840	1.13473
Total	M	4.5828	4.5347	5.2945
	N	145	144	146
	SD	1.56792	1.58075	1.42596

Table 5.3. Summary of the ease of use of each tool.

Regarding to the effect of space on the business processes supported by GSS applications, the results shown in figure 5.2 indicate that the virtual environment is useful in meetings. All the figures show

means higher than $m=4.1$ with standard deviations lower than $sd=1.79$. Specifically, figure 5.2.d indicates that the *VotingFloor* inside *SecondLife* is especially useful for voting. It matches the results obtained for understandability and ease of use. These results are summarized in table 5.4. From this table it is important to see that the means and standard deviations are more positive in the virtual meetings indicating that the barriers of learning new technologies had an impact on the way that the participants experience *SecondLife* and the tools. It matches the personal feedback that was obtained during the virtual meetings. The participants were very receptive of the tools and expressed their interest on using them again in different fields.

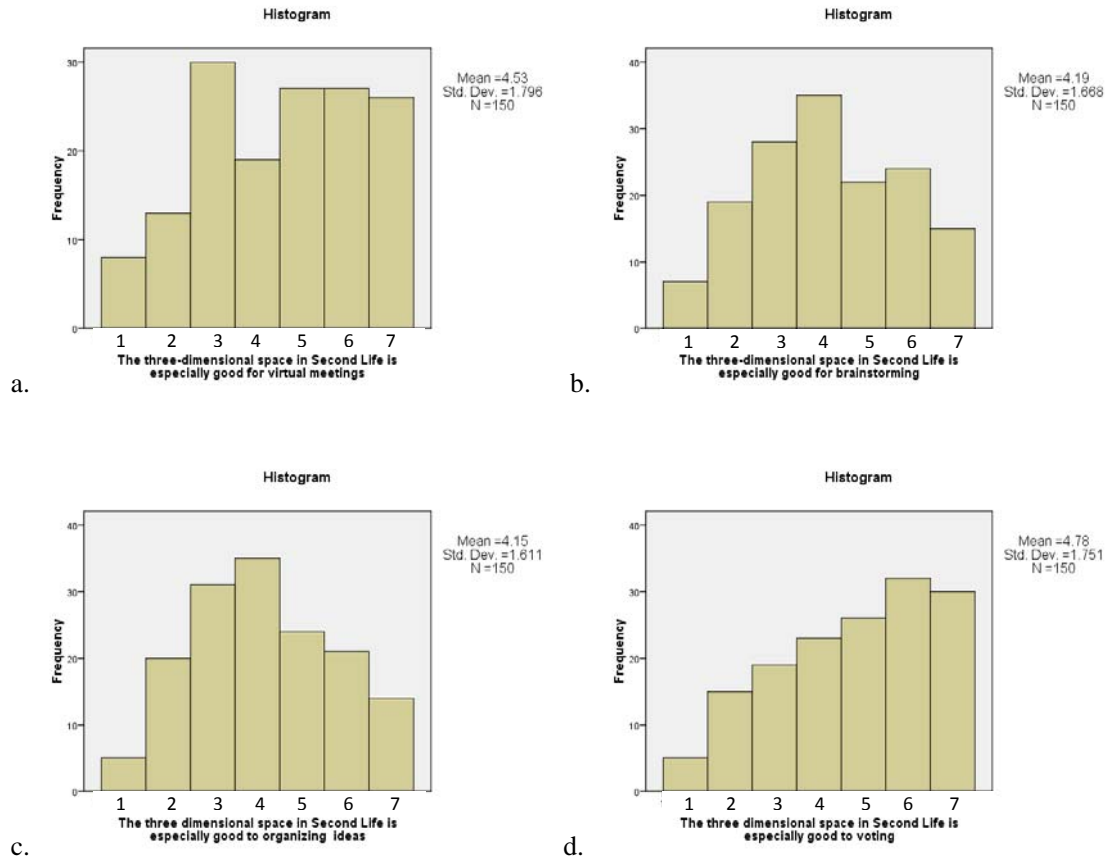

Figure 5.2. Results of impact of space on the business processes supported by GSS tools.

Meeting setting		The three-dimensional space in Second Life is especially good for brainstorming	The three dimensional space in Second Life is especially good to organizing ideas	The three dimensional space in Second Life is especially good to voting
Face-to-face	M	3.48	3.57	4.17
	n	95	95	95
	SD	1.413	1.449	1.693
Virtual	M	5.45	5.19	5.89
	n	53	53	53
	SD	1.353	1.388	1.296
Total	M	4.19	4.15	4.78
	N	148	148	148
	SD	1.680	1.622	1.763

Table 5.4. Summary of impact of space on the business processes supported by GSS tools

About the quality of the meeting, the means are above $m=3.7$ indicating some level of satisfaction (see figures 5.3). Nevertheless, these figures show slight skewness to the left and a peak on level 2 of figure 5.3.b. Not only the interface design had an impact on these measurements. Several other factors, like the facilitator (which was different in all the meetings) and the process, could have had an effect. The results indicate that the participants were overall satisfied with the quality of the meeting ($m=3.8$, $SD=1.8$). The participants in the virtual meeting setting ($m=5.3$, $SD=1.3$) were significantly ($p=.0001$) more satisfied than the participants in the face-to-face setting ($m=3$, $SD=1.3$).

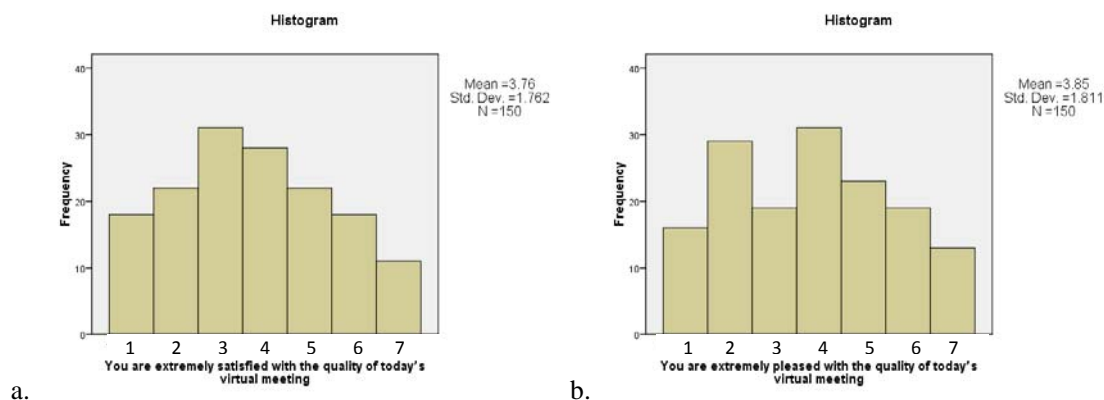

Figure 5.3. Quality experienced by the users.

Figure 5.4 shows the intention of using *SecondLife* for virtual meetings again. There can be seen a bimodal shape which indicates the presence of two subgroups within the sample. Despite the fact that

the mean is close to $m=4$, the standard deviation is $sd=2.24$, quite high for obtaining a strong conclusion about a particular level. Indeed, there were two subgroups: regular users of *SecondLife* and newcomers. It is highly probable that regular users of *SecondLife* will use the environment for future virtual meetings and that is why there is a high peak in level 7. On the other hand, new users could be reluctant to use the tools and *SecondLife* in general, due to lack of intrinsic motivation to try out new information technologies. Specifically, the participants in the virtual setting agreed strongly with the proposition ($m=6$, $SD=1.5$) while the participants in the face-to-face setting are somehow a bit less enthusiast ($m=2.7$, $SD=1.8$).

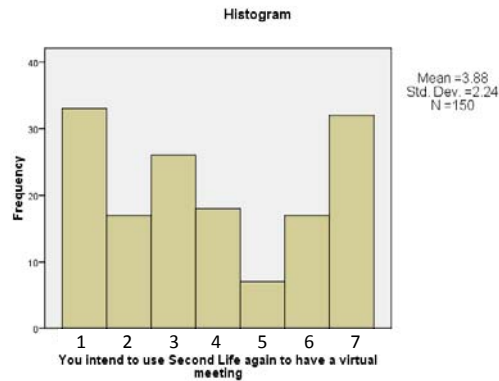

Figure 5.4. Intention of using *SecondLife* for virtual meetings.

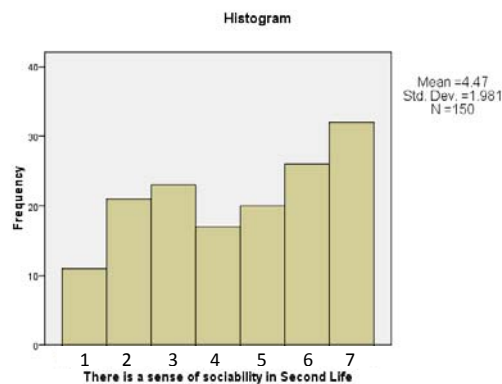

Figure 5.5. Sociability experienced by the users.

Respect to the sociability experienced by the users, figure 5.5 shows again a bimodal shape. Certainly, for current users of virtual worlds this technology represents a way of interacting and communicating that allows for having human contact. Nevertheless, first time users still found virtual worlds as games or chatting tools aimed to spend spare time. Having said that, the results shown in figure 5.5 are interesting because even when the number of users in the virtual meetings was almost a half (i.e. 50) of the face-to-face meetings, the average of the sense of sociability was quite high (around $m=4.47$) taking both groups combined. This means that experienced users of *SecondLife* strongly believe that there is a sense of sociability inside the environment.

In the same way, the tools developed were compared against other tools used for similar purposes (see figures 5.6). All figures show high standard deviations (i.e. around $sd=2$) indicating a low level of

agreement within the group. It is important to mention that the sample size of these variables is less than 150 because not all the participants had used tools like these before. Besides the high standard deviations, the figures show several peaks indicating one more time the presence of subgroups within the sample. Nevertheless, all the mean values appear above $m=3.46$ suggesting good adoption of the tools and *SecondLife* to some extent. Specifically, from figures 5.6.e and 5.6.f it can be seen that the group considers the *VotingFloor* as a better and more enjoyable tool for converging than other electronic meeting tools. This is indicated by the mean values of $m=4.36$ and $m=4.73$, respectively. Figure 5.6.f shows one more time the presence of a subgroup in the sample that didn't find enjoyable the *VotingFloor*.

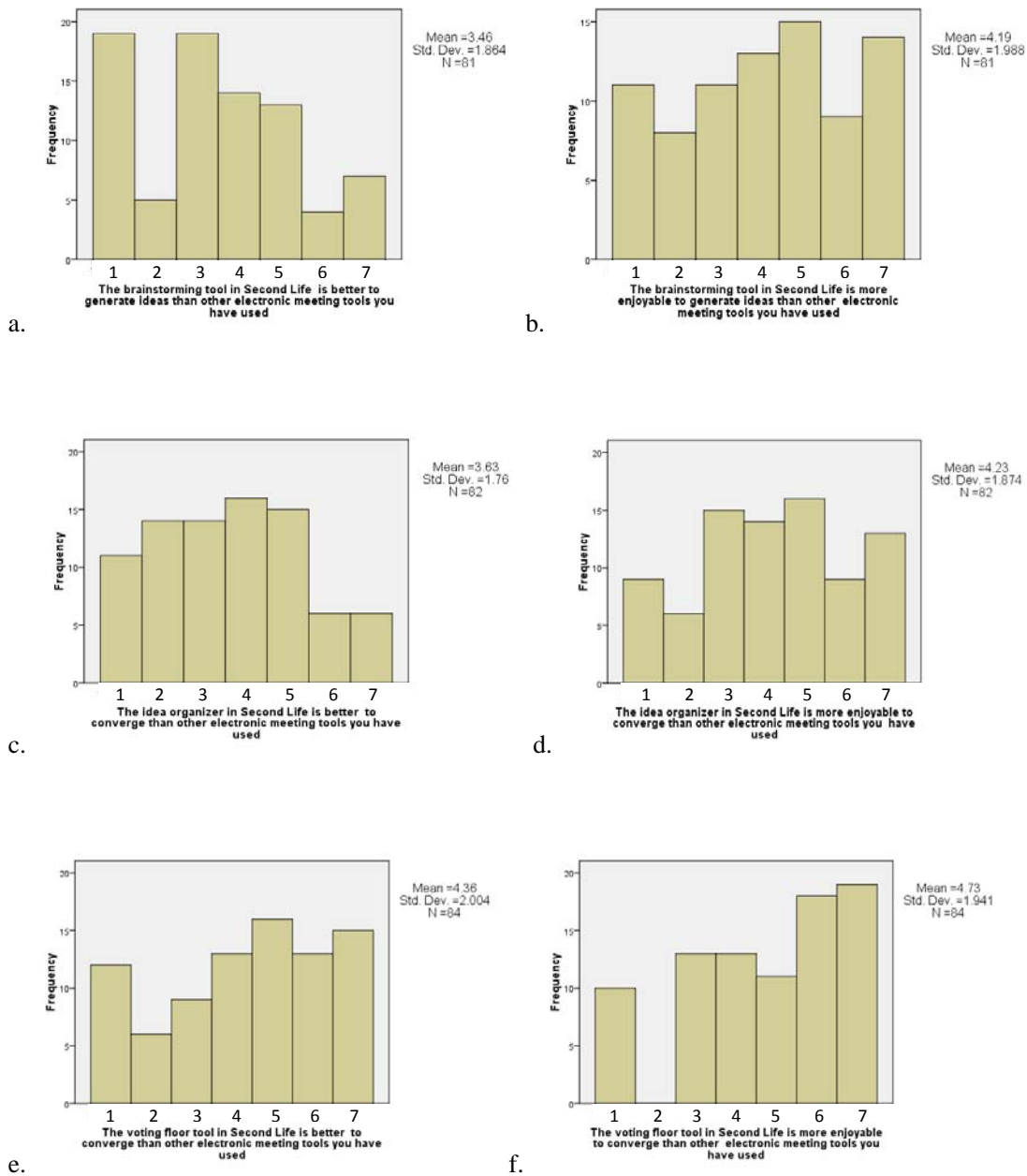

Figure 5.6. Results of comparison between the evaluated tools and similar applications.

5.4 Strong points of the tools

Strong capabilities were identified in both, the tools implemented and *SecondLife* itself. The first interesting feature is the ease of use of the *VotingFloor*. It was very intuitive and the users just needed to move their avatars to cast a vote. It was indeed an application of space to decision making. Another good point was the ability of the *IdeaGenerator* for displaying brainstormed ideas in three dimensions which allowed the participants to have a shared view of their thoughts. Furthermore, *SecondLife* allows the user to leave persistent objects in the space. This implies that they are able to participate in a process spanned in time. One example is when the stacks of ideas in the *IdeaGenerator* remain available for other avatars to interact with them. Also, the animation features in *SecondLife* improves the feeling of presence. For instance the idea cubes in the *IdeaGenerator* are stacked hovering and as soon as one of the ideas from a lower position moves, the ideas above it fall due to gravity. Additionally, the spatial distribution of the tools helps late participants for getting an instant overview of status of the meeting.

But the most remarkable feature was the capability of supporting meetings of groups distributed around the world. Only few professional tools used for CSCW [3] have such functionality (e.g. *ThinkTank* [60]). The tools designed seemed to give a way of interacting that the most advanced technologies for communication, like videoconference, don't offer. With *SecondLife* and specifically the *IdeaGenerator* and *VotingFloor* the participants had the feeling that they were 'next to each other' doing something together as if they were face-to-face even when they were spread over several continents.

5.5 Implications for GSS & SecondLife

The limitations found during the design phase have important implications for both, the continuing use of *SecondLife* for business purposes and specifically the use of *SecondLife* as a *GSS*. If *Linden Labs* does not improve the text input support, it is highly improbable that elaborated processes like brainstorming and collaborative writing succeed. Indeed, any computer application in virtual worlds aimed to interact with a human will require a level of maturity for displaying / introducing text similar to the interfaces of the current operative systems.

Also, for the *GSS* tools developed it is very important to solve the limitations of no anonymity and control of avatars. Nevertheless, it is possible to see some solutions based on scripts of invisibility and access rights for the avatars.

In addition, the future of virtual worlds and their acceptance for using them as platforms for supporting business processes relies in the interoperability available and the development of standards. For instance, there are several critics about the reliability of *SecondLife* [53] and its impact on the performance of businesses already established inside. Indeed, that kind of faults were experienced several times during this project. Sometimes there was deficient or no voice communication at all, delays of the meetings, and even cancelling the meetings was necessary due to maintenance of the servers. Undoubtedly, it is not possible to run critical operations in a platform with such performance; In fact, it is not possible to rely in a platform on which the owner of the business does not have any kind of control. Therefore, it is indispensable that the companies have the opportunity of developing their own virtual worlds with the possibility of inter-connecting them. Some solutions have been developed for this (see [58] and [59]) and that is the main aim of the presence of companies like IBM and SUN Microsystems inside *SecondLife*.

6 Conclusions

Sub-question 1 about the implementation of applications inside a virtual world can be answered from an engineering point of view. Despite all the limitations that *SecondLife* and its virtual worlds peers have, it can be concluded that these platforms are feasible for developing applications as long as they are in research stages. From this project it was identified a support to the visualization of the parallel contribution in meetings as well as for visualization of the process. The main advantages over other technologies were the ability of *sharing a view within a group* and having *an agenda embedded in the spatial layout of the virtual setting* even when the group was geographically distributed.

Sub-question 2 about experience can be answered from the results obtained with the experiment. Overall, it can be concluded that the effect of the representation of space is positive in the sense that the users found the 3D interface understandable and easy to use (mean results were higher than $m=4.4$ in the scale that ranges from 1 to 7). Similarly, the users experienced a sense of sociability inside the environment (mean equal to $m=4.47$).

For the support of brainstorming, organizing ideas and decision making, the participants found the space provided by virtual worlds specially good (mean results were higher than $m=4.15$ in the scale that ranges from 1 to 7). Furthermore when they were asked to compare the virtual tools with previous tools that they had used before for the same purposes, the mean results show values higher than $m=3.6$ in the scale from 1 to 7 indicating acceptance to some extent. Nevertheless, it is very important to point out the differences between the results obtained from the groups (i.e. virtual meetings and face-to-face meetings). From the virtual setting the feedback was more positive. This can be explained by two factors, first most people in the FTF (face-to-face) meetings had never used *Secondlife*. The participants in the virtual meetings were more experienced in *SecondLife* and felt more familiar with the interface and thus had a better experience when using the tools. Second explanation can be found in the fact that *Secondlife* is not really developed for FTF and functionalities like audio cannot be used within the room.

Finally, this research represents the third iteration of the design-science paradigm applied to study the effects of space on GSS tools. The results obtained indicate that the development is in a good direction and that further improvements of features like the text input, avoiding visibility for anonymity, and control of actions of the users could give better results each time. It was possible to see that, according to the groupware grid (see figure 3.1), *SecondLife* and specifically the *VotingFloor* and the *IdeaGenerator* offer good support to the visualization of the process as well as of the parallel contribution. Nevertheless, the support for information access is poor due to the introducing / displaying text limitations.

The results show that the feeling of being in a shared space has a positive effect on the experience of Group Support Systems tools. Besides, virtual environments offer the possibility of joining other technologies like voice over IP, video streaming, text chatting and sharing documents.

7 Future research

Further iterations of the design-science approach should be done in order to get stronger conclusions as well as better applications inside virtual worlds. Specifically, for the next iteration it is suggested to improve further the capabilities of introducing/displaying text in order to make the tools more intuitive. Also a different interface for the brainstorming / organizing tool could be suggested with the purpose of splitting the sequence of creating an idea, moving it, editing it, and check the ideas created by other avatars. In the same way other aspects as evaluation of anonymity versus presence and integration of video streaming can be studied.

8 Reflection

The master in science Operations Management and Logistics helped me to mature. My development was not only academically but personal. I had to face challenges mostly related with the methodology followed in The Netherlands which is quite different to that from Colombia.

Within the program I followed very interesting courses that allowed me to have a broader knowledge of the engineering applied science. Furthermore, I took elective courses from the Information Systems sub-department that I found of good relevance and applicable to situations on real companies (e.g. Software Management, Process Mining and Enterprise Information Systems).

Particularly, I found the Software Management course very interesting because the experience of professor Michiel Van Genuchten and the collaborative nature of the tasks in the course. The fact that we had to develop a tool in a group with people distributed in different parts of the world was fascinating to me. Furthermore, I was applying concepts that I enjoy like design and implementation in Software Engineering. I enjoyed the project very much and it was reflected in the results. Thanks to that course the current master thesis project started. And, as it was for the course, it involved several interesting aspects for me like designing, programming and testing with professionals from real companies. Even more interesting was that the project included people from all over the world and we got positive feedback from several perspectives.

In conclusion, I could say that to develop a project like this one my background in software developing was not enough. The managerial concepts that I learned from several courses of the faculty helped me a lot. These concepts were more related with data research, software management, and performance enhancement. I can say that my experience in the TU/e allowed me to develop skills for working in teams, project management, technical aspects and communication. Beyond that, the university allowed me to be stronger and more mature when facing difficult situations.

9 References

1. Shaw, M. (1981) "Group Dynamics: The Psychology of Small Group Behavior", McGraw-Hill Vol. 3d ed. New York,
2. Panko, R. R. (1994) "Managerial communication patterns", Journal of Organizational Computing Vol. 2, issue 1
3. Baecker, R. (1991) "New Paradigms for Computing in the Nineties", Proceedings Graphics Interface 91
4. Power, D. J. (2007) "A Brief History of Decision Support Systems", DSSresources.com issue 4.0
5. Nunamaker, J. F. et al. (1997) "Lessons from a Dozen Years of Group Support Systems Research: A Discussion of Lab and Field Findings", Journal of Management Information Systems Vol. 13, issue 3
6. Genuchten, M. Van, Vogel, D., Bemelmans, T. M. A., and Rutkowski, A.-F. (2002) "Group Support Systems and Virtual Collaboration: The HKNET Project", Group Decision and Negotiation Vol. 11,
7. De Vreede, G., Davison, R., and Briggs, R. (2003) "How a silver bullet may lose its shine", Communications of the ACM Vol. 46, issue 8
8. Kerr, D. (2004) "Divergent and Convergent Idea Generation in Teams: A Comparison of Computer-Mediated and Face-to-Face Communication", Group Decision and Negotiation Vol. 13,
9. Isenberg, D. J. (1986) "Group polarization: A critical review and metaanalysis", J Personality Social Psych Vol. 50, issue 6
10. Genuchten, M. Van, Bemelmans, T. M. A., Verveen, S., Schuwer, R., and De Waart, J. (2008) "GroupIntelligence: Automated Support For Capitalizing On GroupKnowledge", Whitepaper
11. Chen, H., Hsu, P., Orwig, R., Hoopes, L, and Nunamaker, J. F. et al. (1994) "Automatic Concept Classification of Text from Electronic Meetings", Communications of the ACM Vol. 37, issue 10
12. Talbott, S. (1995) Chapter: Thoughts on a Group Support System. Book: The Future Does Not Compute: Transcending the Machines in Our Midst. O'Reilly & Associates.
13. Qvortrup, L. (2002) "Virtual Space: Spatiality in Virtual Inhabited 3D Worlds". Springer.
14. Bailenson, J. and Blascovich, J. (2004) "Berkshire Encyclopedia of Human-Computer Interaction". Definition of Avatar.
15. Donath, J. (2007) "Virtually Trustworthy", Science Vol. 317, issue 1.
16. Harry, D. (2008) "Information Spaces" <http://web.media.mit.edu/~dharry/infospaces/>

17. Bailenson, J.; Beall, A.; Loomis, J.; Blascovich, J. and Turk, M. (2004) "Transformed Social Interaction: Decoupling Representation from Behavior and Form in Collaborative Virtual Environments", *Presence* Vol. 13, issue 4
18. Fitzpatrick, G.; Kaplan, S.; and Mansfield, T. (1996) "Physical Spaces, Virtual Places and Social Worlds: A study of work in the virtual", *ACM Computer Supported Cooperative Work '96*
19. Rutkowski, A.-F.; Saunders, C.; Vogel, D. and Genuchten, M. Van. (2007) "Is It Already 4 a.m. in Your Time Zone? Focus Immersion and Temporal Dissociation in Virtual Teams", *Small Group Research* Vol. 38, issue 1
20. Kanawattanachai, P. and Yoo, Y. (2007) "The Impact of Knowledge Coordination on Virtual Team Performance Over Time", *MIS Quarterly* Vol. 31, issue 4
21. Lu, M.; Watson-Manheim, M.; Chudoba, K. and Wynn, E. (2006) "Virtuality and Team Performance: Understanding the Impact of Variety of Practices", *Journal of Global Information Technology Management* Vol. 9, issue 1
22. Driver, E. and Jackson, P. (2008) "Getting Real Work Done In Virtual Worlds", *Forrester*
23. Benford, S.; Greenhalgh, C.; Rodden, T.; and Pycock, J. (2001) "Collaborative Virtual Environments", *Communications of the ACM* Vol. 44, issue 7
24. Churchill, E. F. and Snowdon, D. (1998) "Collaborative Virtual Environments: An introductory Review of Issues and Systems", *Virtual Reality* Vol. 3,
25. Bentley, R.; Rodden, T.; Sawyer, P.; Sommerville, I.; Hughes, J.; Randall, D. and Shapiro, D. (1992) "Ethnographically informed systems design for air traffic control", *Proceedings of CSCW '92*
26. Harrison, S. and Dourish, P. (1996) "Re-Place-ing Space: The Roles of Place and Space in Collaborative Systems", *Computer Supported Cooperative Work '96*
27. Bailenson, J. (2007) "Transformed Social Interaction in Collaborative Virtual Environments", *Stanford University, Department of Communication*
28. Bailenson, J.; Beall, A. and Blascovich, J. (2002) "Gaze and task performance in shared virtual environments", *The journal of visualization and computer animation* Vol. 13,
29. Yee, N. (2008) "The Labor of Fun: How Video Games Blur the Boundaries of Work and Play", *Games and Culture* Vol. 1, issue 1
30. Bowers, J.; Pycock, J, and O'Brien, J. (1996) "Talk and Embodiment in Collaborative Virtual Environments", *Chi '96*
31. Brna, P. and Aspin, R. (1998) "Collaboration in a virtual world: support for conceptual learning?", *Education and Information Technologies* Vol. 3,
32. Bochenek, G. and Ragusa, J. (2003) "Virtual (3D) Collaborative Environments: An Improved Environment for Integrated Product Team Interaction?", *Hawaii International Conference on System Sciences*
33. Billingham, M. and Kato, H. (2002) "Collaborative Augmented Reality", *Communications of the ACM* Vol. 45, issue 7

34. Hughes, C. and Stapleton, C. (2005) "The Shared Imagination: Creative Collaboration in Augmented Virtuality", Proceedings of Human Computer Interaction International 2005
35. Tan, D.; Poupyrev, I.; Billingham, M.; Kato, H.; Regenbrecht, H. and Tetsutani, N. (2001) "The best of two worlds: Merging virtual and real for face to face collaboration", IEEE International Conference on Multimedia and Expo
36. NMC (2008) "New Media Consortium (NMC) Campus Observer" <http://sl.nmc.org/about/>
37. GroupVision (2008) "Alpine Executive Center - MeetingSupport" <http://www.groupvision.ch/>
38. Power, D. J. (2008) "Decision Support World" <http://decisionsupportworld.com/>
39. Sia et al. (2002) "Group Polarization and Computer-Mediated Communication: Effects of Communication Cues, Social Presence, and Anonymity", Information Systems Research. Vol. 13, No. 1. pp 77-90.
40. Briggs, R.O. (1994) "The team theory of group productivity and its application to the development and testing of electronic group support technology". Unpublished doctoral dissertation, University of Arizona.
41. Hevner, A.; March, S; Park, J. and Ram, S. (2004). Design Science in Information Systems Research, MIS Quarterly, 28(1), pp. 75-105.
42. Stanney, K. (2003) "Virtual Environments. The Human-Computer Interaction Handbook. Fundamentals, Evolving Technologies and Emerging Applications". J.A. Jacko and A. Sears, Editors. Lawrence Erlbaum Associates, Publishers: Mahwah, NJ. pp. 621-638.
43. Bowman, D.; Kruijff, E.; LaViola Jr., J. and Poupyrev, I. (2001) "An Introduction to 3-D User Interface Design". Presence Vol. 10, No. 1. pp 96-108.
44. Power, D. J. (2008) "What rules should guide DSS user interface design?" <http://dssresources.com/faq/index.php?action=artikel&id=143>
45. Maznevski, M.L., and Chudoba, K.M. (2000) "Bridging Space Over Time: Global Virtual Team Dynamics and Effectiveness". Organization Science, 11(5), 473-492.
46. Saunders, C.; Van Slyke, C. and Vogel, D. (2004). "My Time or Yours? Managing Time Visions in Global Virtual Teams". Academy of Management Executive, 18(1), 19-31.
47. Piccoli, G. and Ives, B. (2000) "Virtual teams: managerial behavior control's impact on team effectiveness". ICIS 2000, pp. 575-580.
48. Griffith, T.; Sawyer, J. and Neale, M. (2003) "Virtualness and Knowledge in Teams: Managing the Love Triangle of Organizations, Individuals, and Information Technology". MIS Quarterly, 27(2), 265.
49. Robey, D.; Khoo, H.M., and Powers, C. (2000) "Situating Learning in Cross-Functional Virtual Teams". IEEE Transactions on Professional Communication, 43(1), 51-66.
50. *SecondLife* (2008) www.secondlife.com
51. Hobbs, M.; Gordon, M. and Brown, E. (2006) "A Virtual World Environment for Group Work" Anglia Ruskin University, Computing Department, Cambridge.

-
52. Romano, N.; Nunamaker, J.; Briggs, R.; and Vogel, D. (1998) "Architecture, Design and Development of an HTML/JavaScript Web-Based Group Support System," *Journal of the American Society for Information Science (JASIS)*, 49(7), pp. 649-667.
 53. Swaminathan, K. S. (2007) "On the Edge, Virtual worlds, real business?". *Accenture. Outlook*, September. No. 3.
 54. Gefen, D. and Straub D. W. (2004) "Consumer trust in B2C e-commerce and the importance of social presence: experiments in e-products and e-services". *Omega*, 32, 407-424.
 55. Pavlou, Paul A. and M. Fygenson (2006) "Understanding and Predicting Electronic Commerce Adoption: An Extension of the Theory of Planned Behavior" *MISQ*, 30(1), 115-143.
 56. Mun Y. Yi and Yujong Hwang (2003) "Predicting the use of web-based information systems: self-efficacy, enjoyment, learning goal orientation, and the technology acceptance model". Moore School of Business, University of South Carolina, Columbia, SC 29208, USA.
 57. SDL Forum Society (2008) <http://www.sdl-forum.org/SDL/index.htm>
 58. Croquet Consortium (2008) http://croquetconsortium.org/index.php/Main_Page
 59. Forterra (2008) <http://www.forterrainc.com/>
 60. GroupSystems (2008) <http://www.groupsystems.com>
 61. There (2008) <http://www.there.com/>

10 Appendix A. SDL and MSC models of relevant parts of the tools.

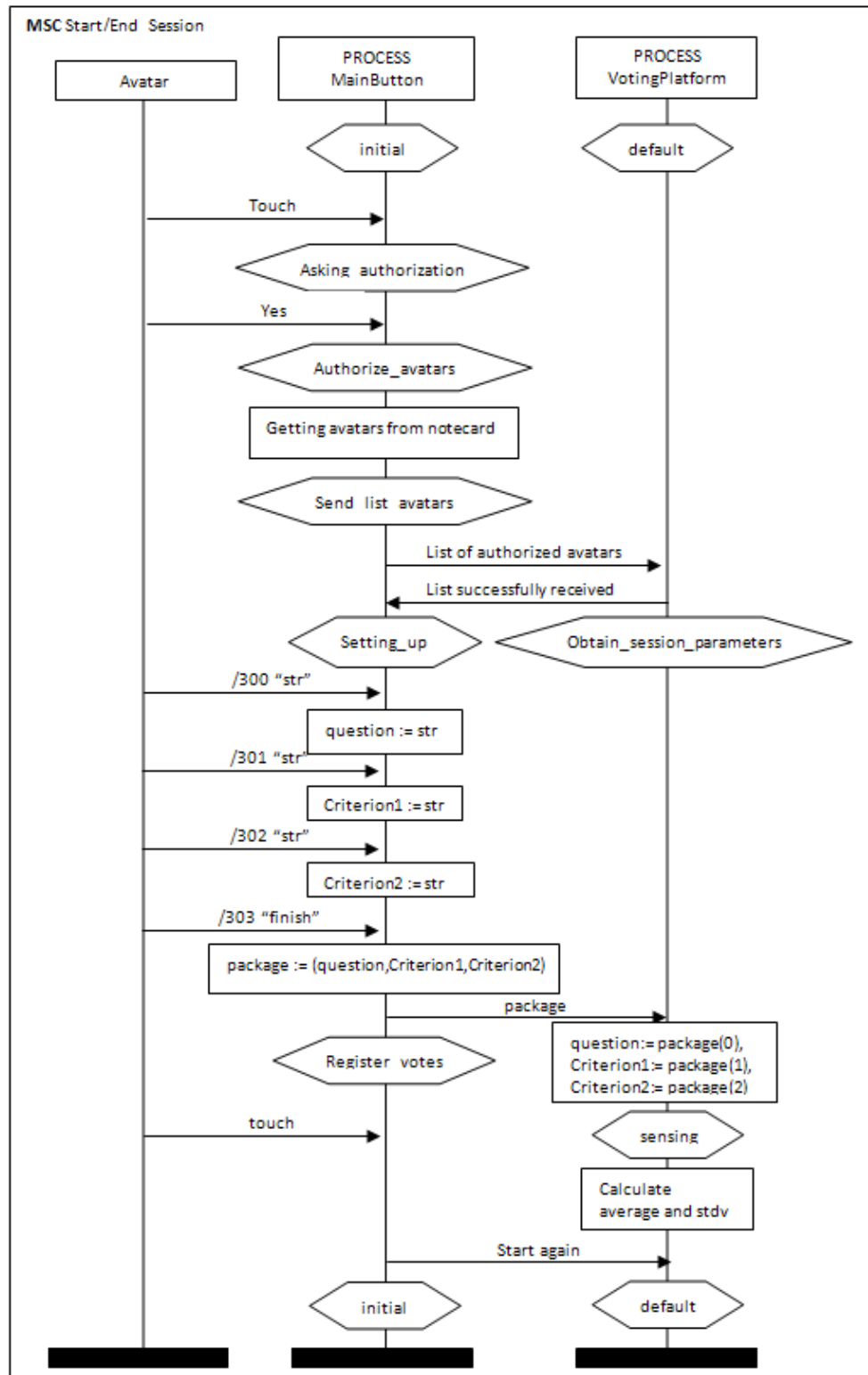
Figure 10.1. MSC of the start / end session of the *VotingFloor*

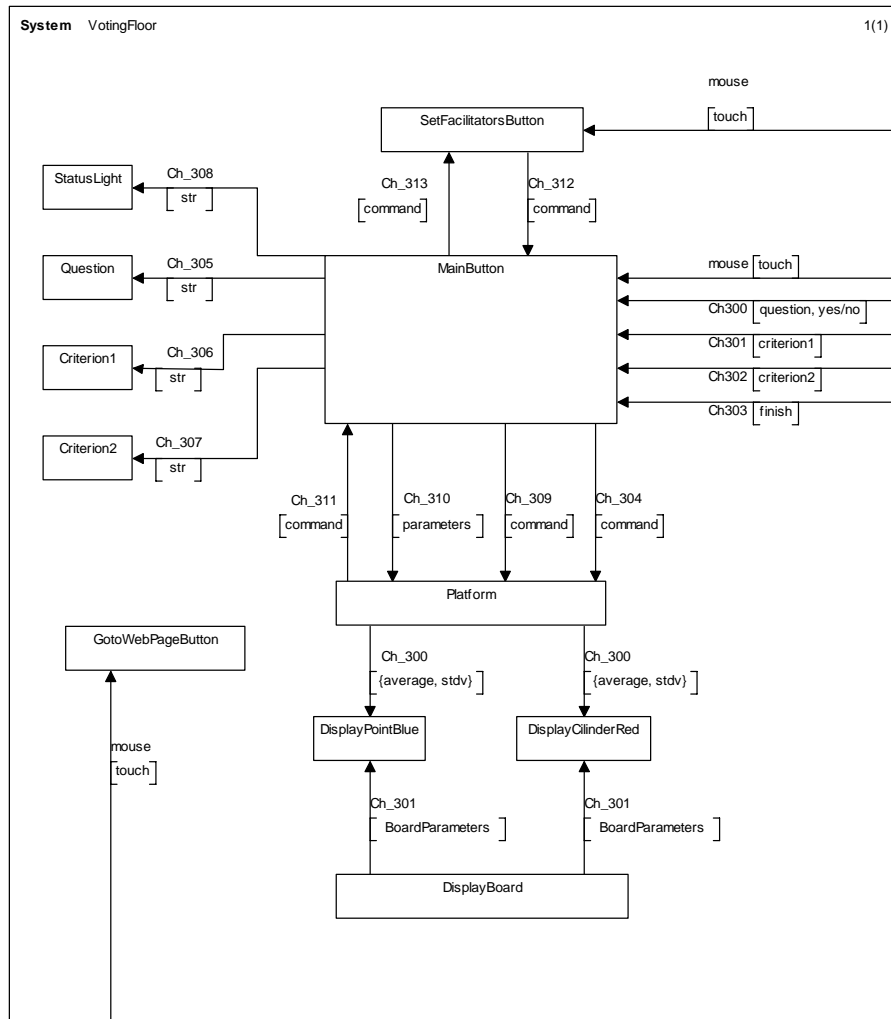
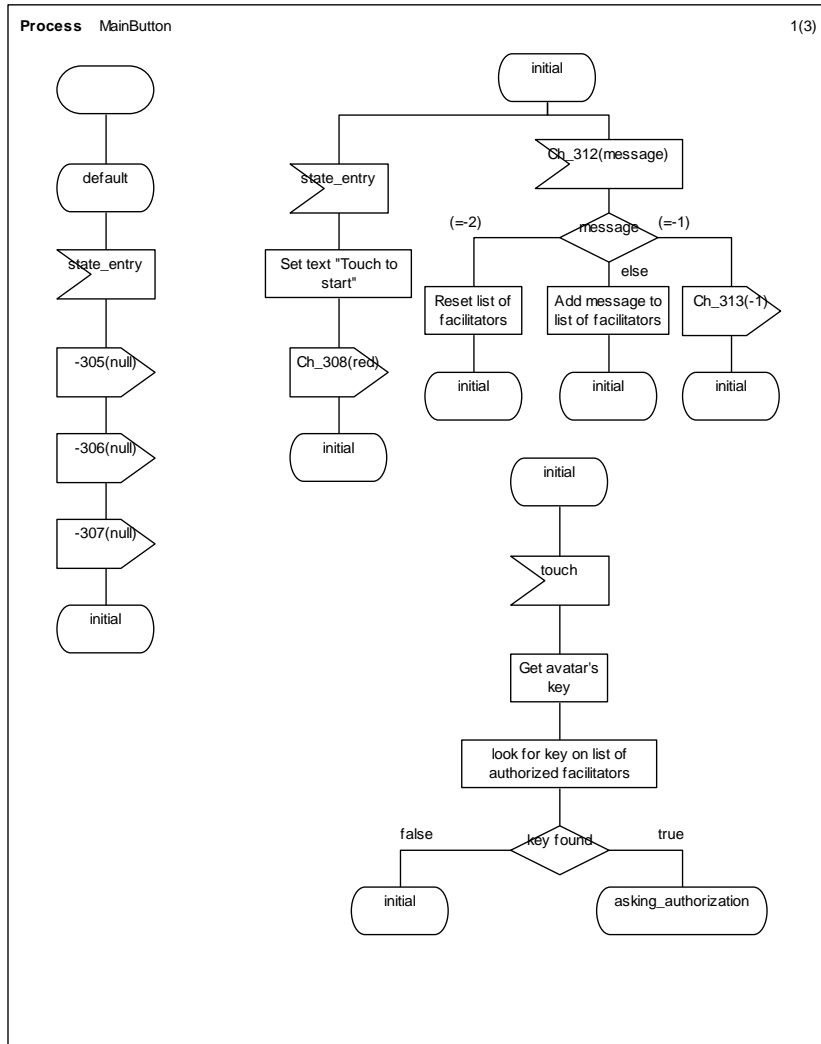
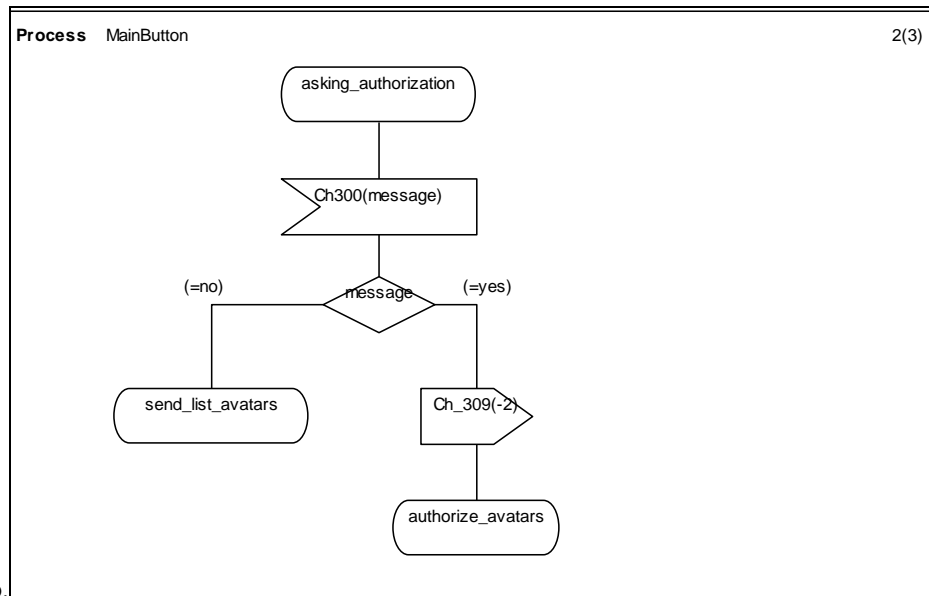

Figure 10.2. SDL model showing some elements and channels of the *VotingFloor*



a.



b.

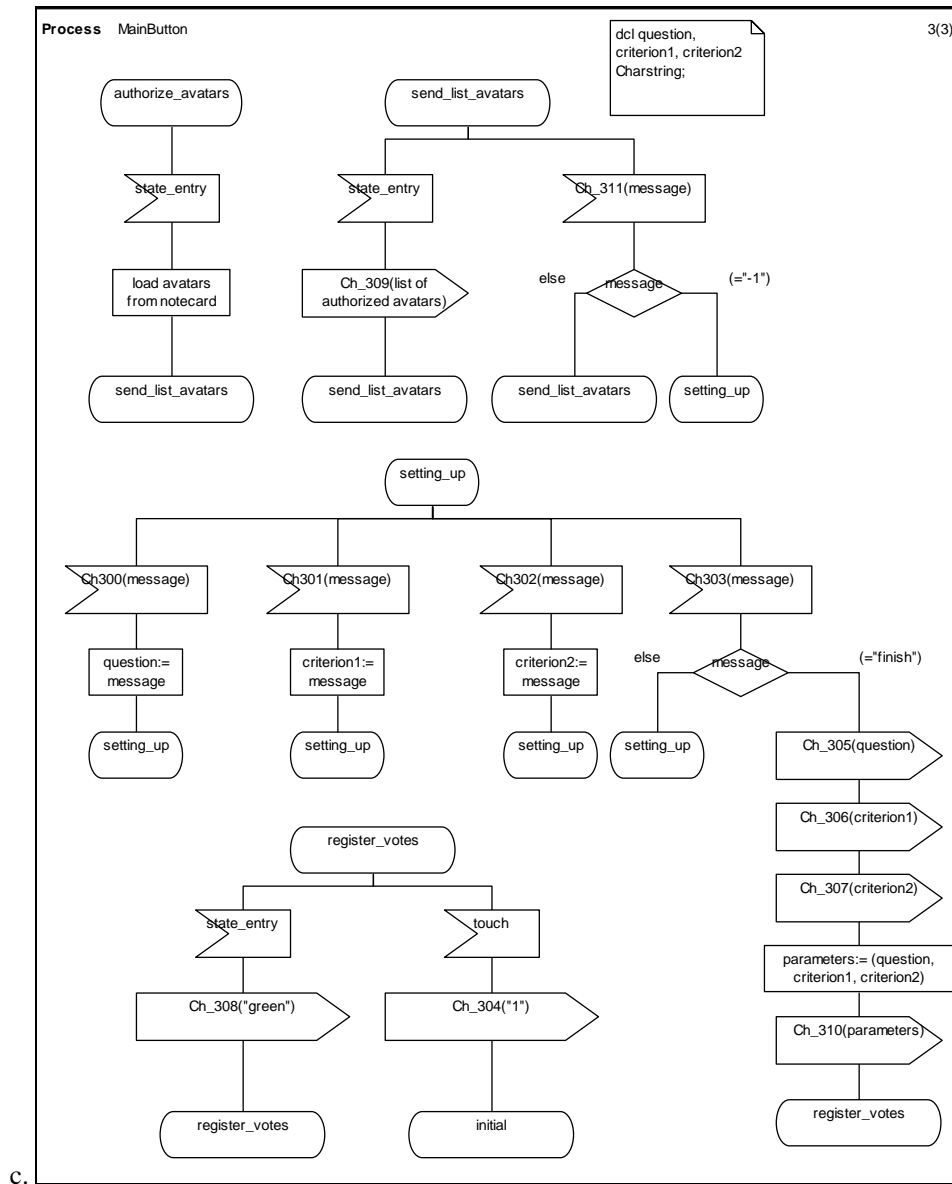

c.

Figure 10.3. SDL model of the script controlling the MainButton of the *VotingFloor*.

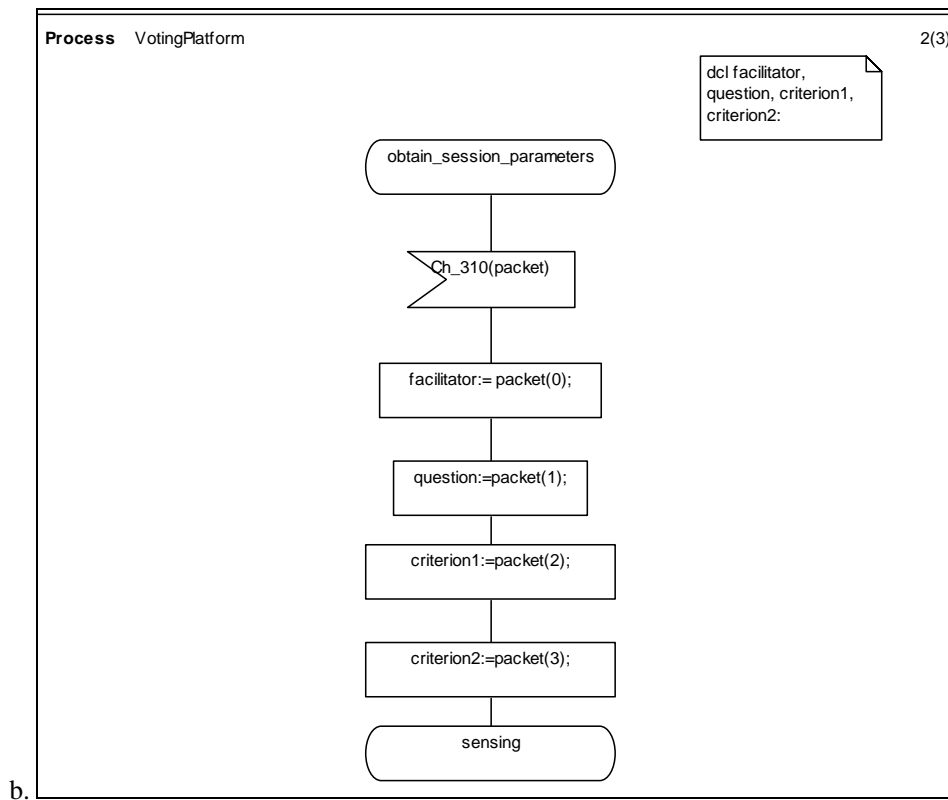
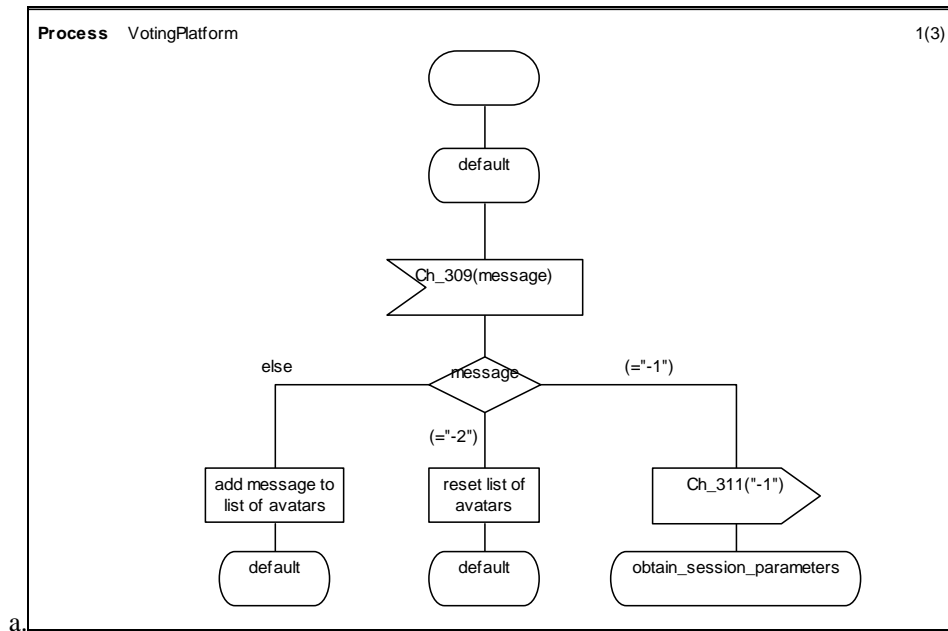

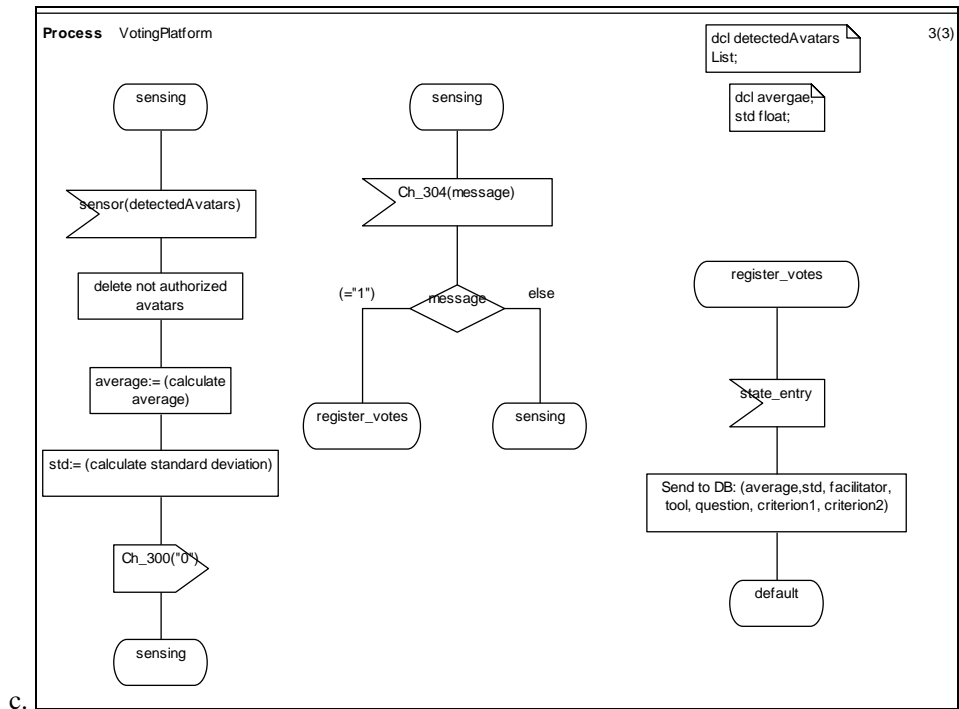

Figure 10.4. SDL model of the script controlling the platform of the *VotingFloor*.

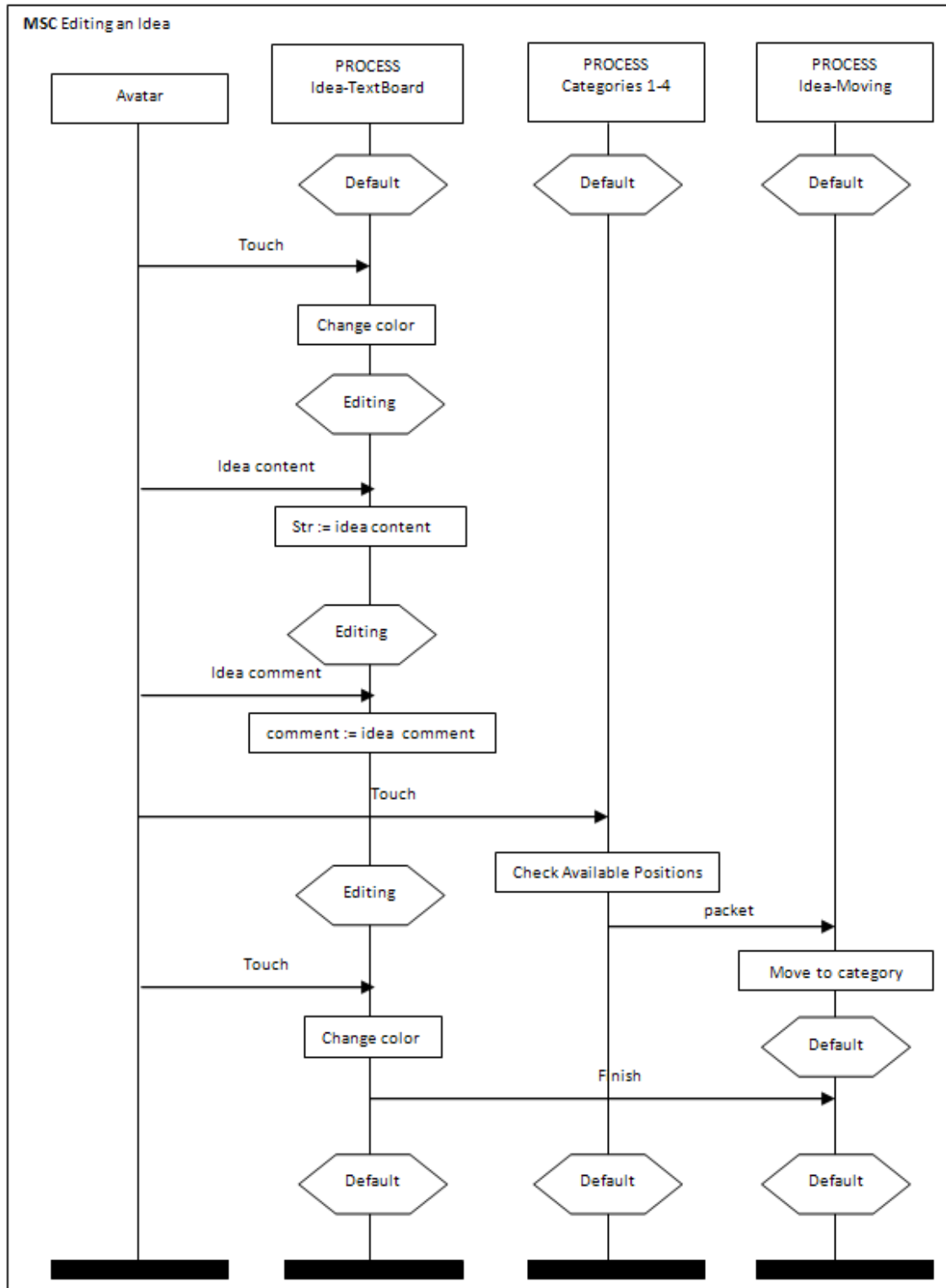

Figure 10.5. MSC of the edition of an idea in the *IdeaGenerator*

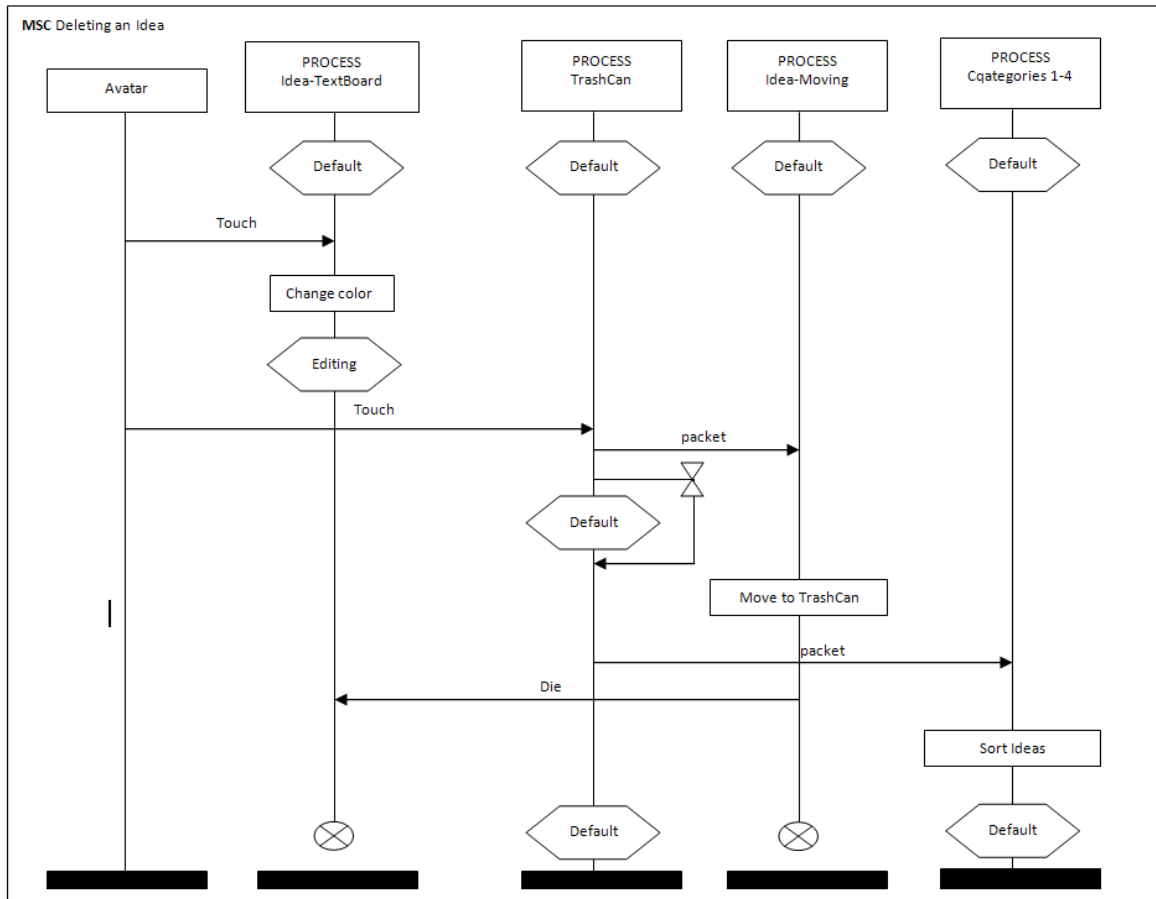

Figure 10.6. MSC of the deletion of an idea in the *IdeaGenerator*

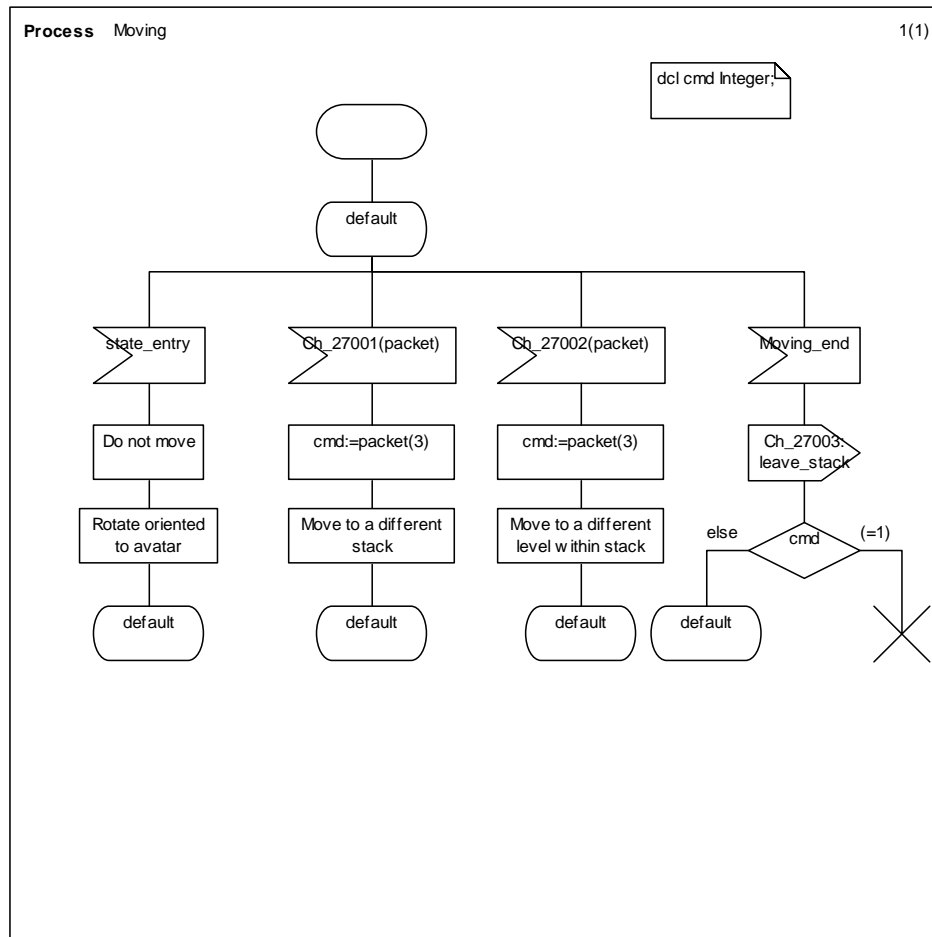
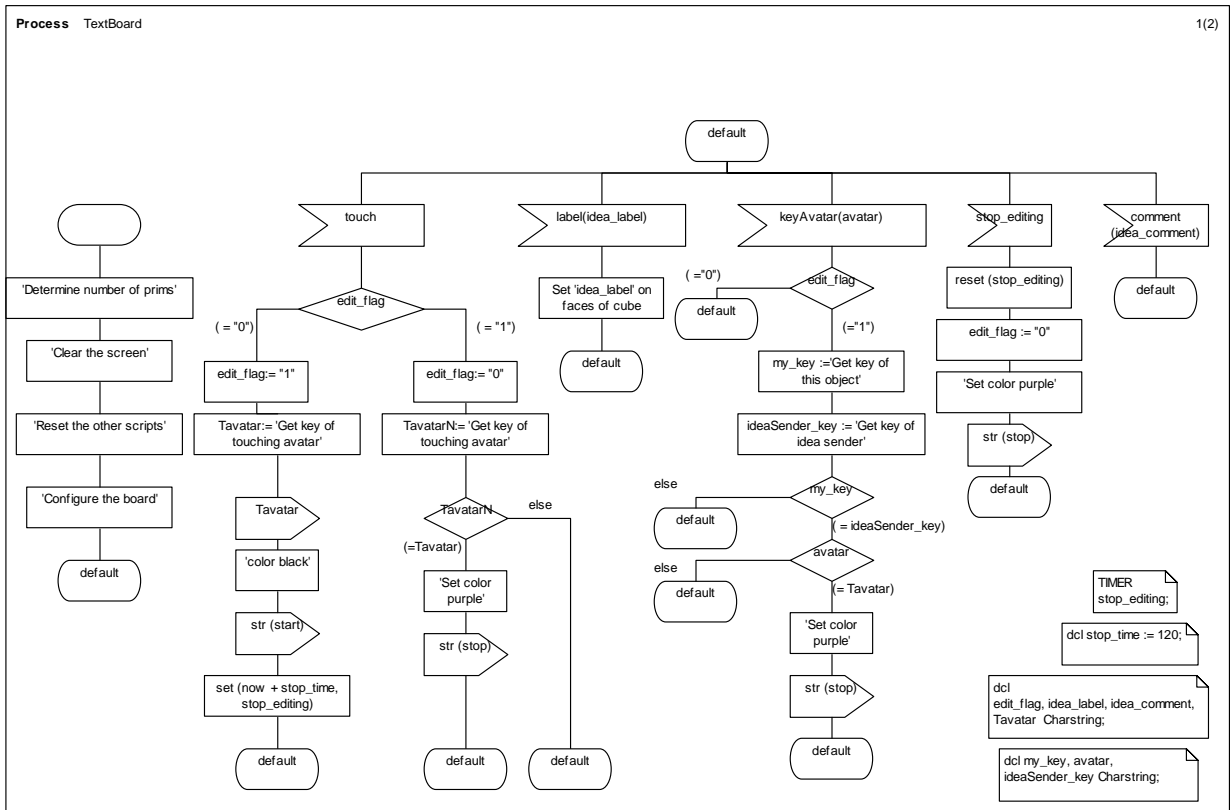
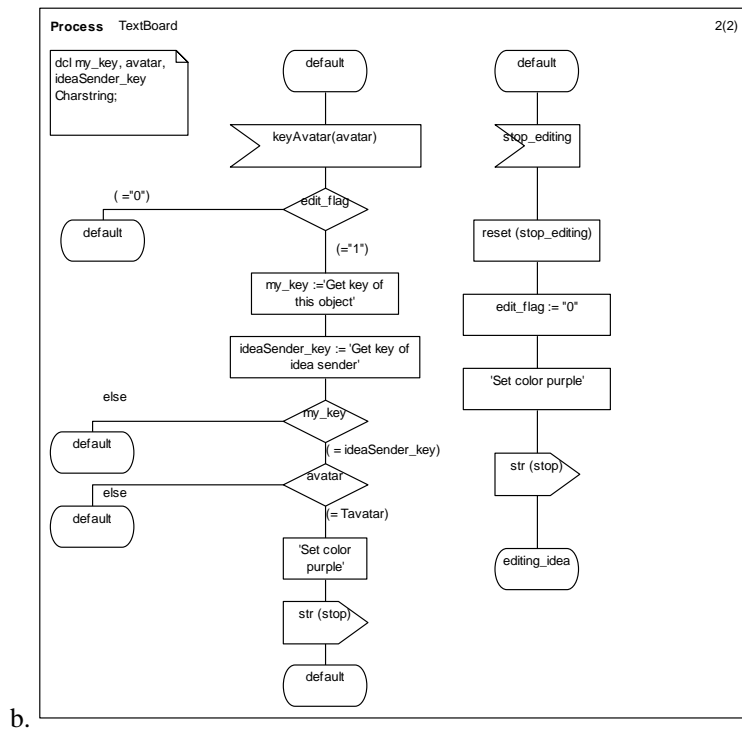

Figure 10.7. SDL model of the script controlling the movements of an idea in the *IdeaGenerator*



a.



b.

Figure 10.8. SDL model of the script controlling an idea in the *IdeaGenerator*

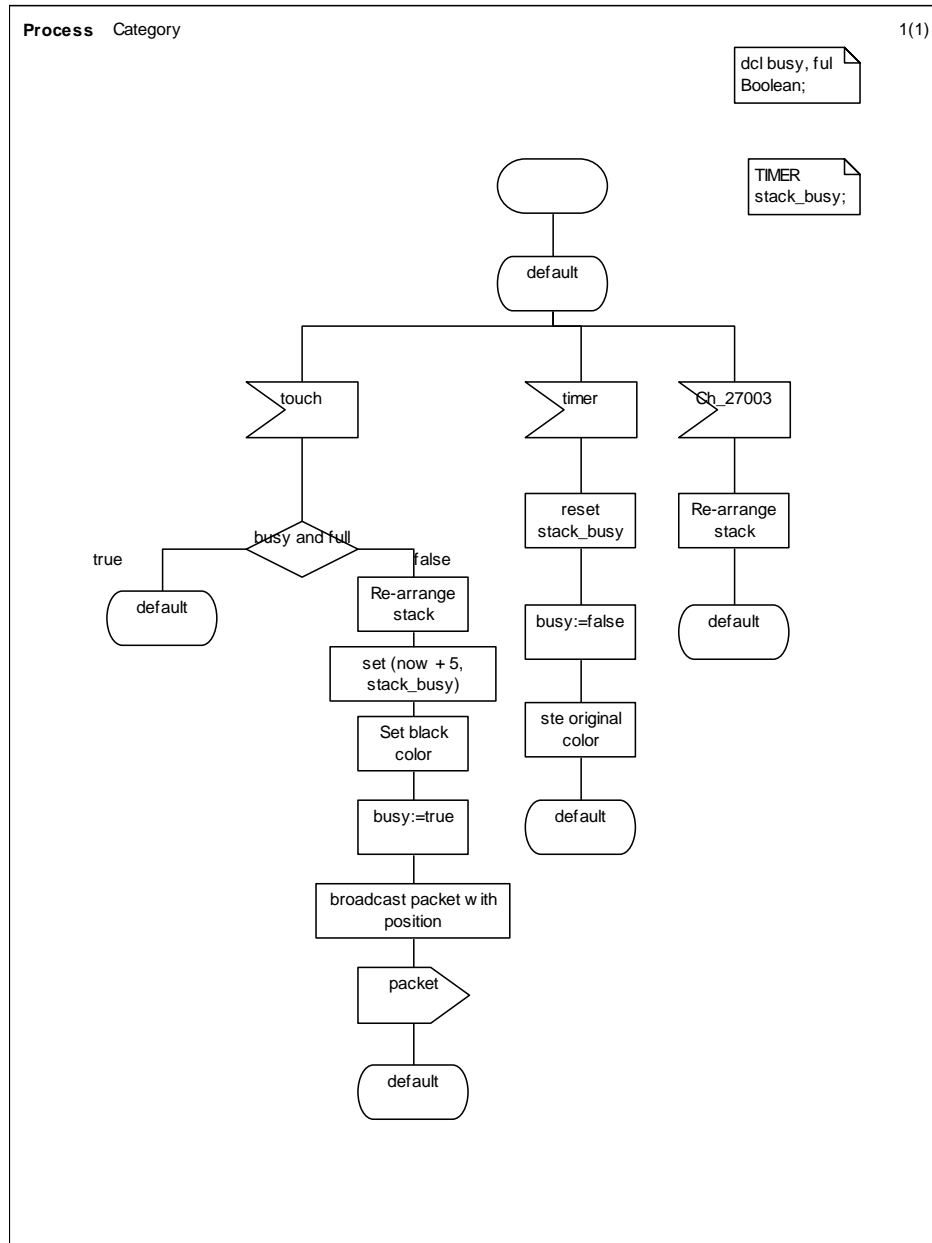

Figure 10.9. SDL model of the script controlling a category in the *IdeaGenerator*

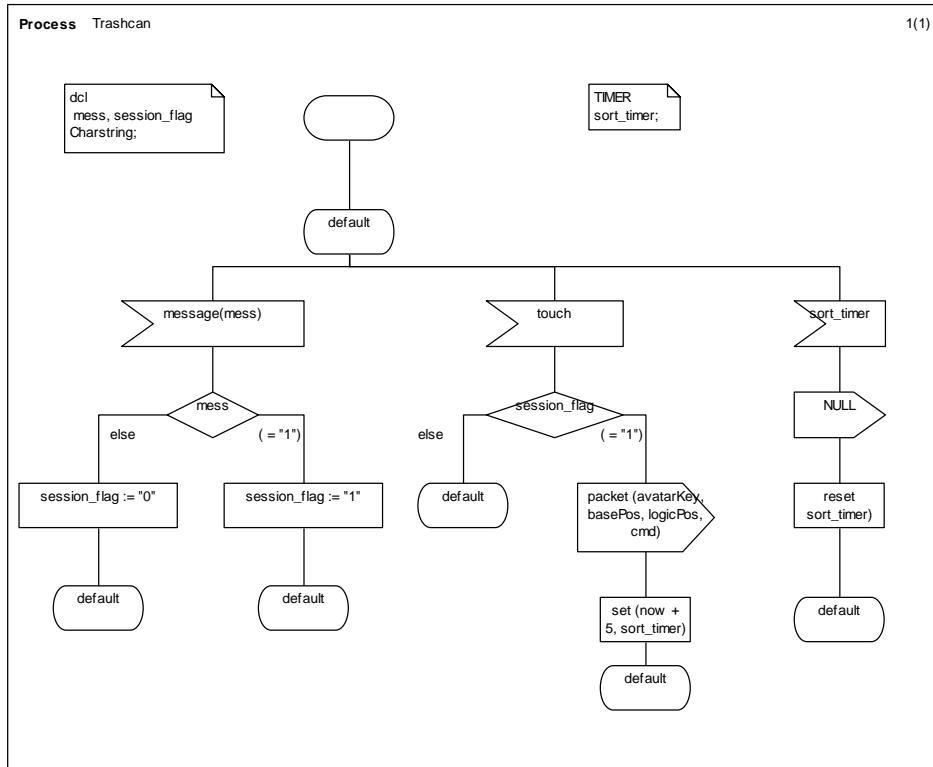

Figure 10.10. SDL model of the script controlling the trash can in the *IdeaGenerator*

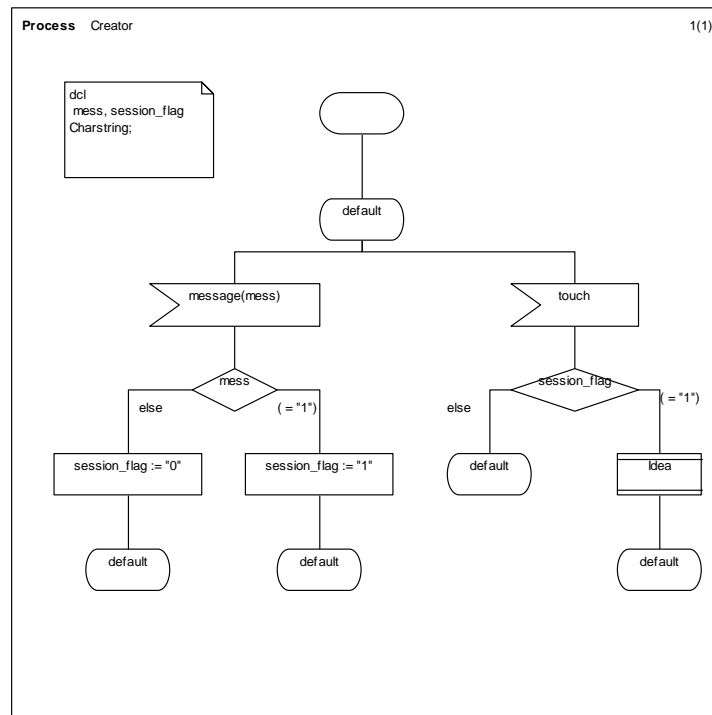

Figure 10.11. SDL model of the script controlling the Light bulb / creator in the *IdeaGenerator*